

PHYSICS

CHEMISTRY  
BIOLOGY

ENGINEERING



LD DIDACTIC

P5.8.6.1

## Diode Laser

4747105 EN



**LEYBOLD®**





## Laser Sicherheitshinweise

Hiermit erklärt die Firma LD Didactic GmbH,  
dass es sich bei dem angebotenen Lasersystem um einen Aufbau handelt, der sowohl in  
Komponenten als auch im fertigen Aufbau einem Laser der Klasse 3A, 3B oder 4 nach DIN EN 60  
825-1 entspricht. Typischerweise ist die Pumpdiode eine Nd:YAG Laser Klasse 4, ein HeNe Laser mit  
Auskoppler Klasse 3A, aber ein HeNe mit zwei hochreflektierenden Spiegeln nur Klasse 1. Bitte die  
Anleitung oder Aufkleber beachten.

Aus Haftungsgründen dürfen diese Geräte oder Gerätesammlungen nicht an Privatleute verkauft  
werden. Der Einsatz von Lasern oberhalb Klasse 2 an allgemeinbildenden Schulen ist in  
Deutschland nicht gestattet.

Gewerbliche Abnehmer, Schulen und Universitäten werden hiermit darauf hingewiesen, dass aus dem  
missbräuchlichen Betrieb der Geräte ein Verletzungsrisiko, speziell für die Augen, resultiert.

Dem Benutzer obliegt insbesondere:

- Die relevanten Unfallverhütungsvorschriften zu beachten, zur Zeit beispielsweise BGV B2 und BGI 832
  - die OstrV zu beachten „Verordnung zum Schutz der Beschäftigten vor Gefährdungen durch künstliche optische Strahlung“
  - Der Betrieb der Geräte muss rechtzeitig beim Gewerbeaufsichtsamt und der Berufsgenossenschaft angezeigt werden.
  - Der Betreiber muss schriftlich einen Laserschutzbeauftragten benennen, der für die Einhaltung der Schutzmaßnahmen verantwortlich ist.
  - Die Geräte sind nur für den Betrieb in umschlossenen Räumen vorgesehen, deren Wände die Ausbreitung des Laserstrahls begrenzen.
  - Der Laserbereich ist deutlich und dauerhaft zu kennzeichnen.
  - Ab Laserklasse 4 ist eine Laser-Warnleuchte am Raumzugang notwendig.
  
  - Die Geräte sind zur Lehre und Ausbildung in Berufsschulen, Universitäten oder ähnlichen Einrichtungen gedacht.
  - Die Geräte nur innerhalb der in den Anleitungen vorgegebenen Betriebsbedingungen betreiben.
  - Die Geräte nur von entsprechend unterwiesenen Mitarbeitern und Studierenden benutzen lassen.
- Bei Handhabung des Gerätes durch Studenten müssen diese von entsprechend geschultem Personal überwacht werden.



Als praktische Ratschläge:

- Vor dem Einschalten auf Beschädigungen prüfen
- Nicht in den Strahl blicken
- Den Laserstrahl so führen, dass sich keine Personen, Kinder oder Tiere ungewollt im Strahlbereich befinden können
- Den Laserstrahl nicht auf reflektierende Flächen oder in den freien Raum richten
- Nicht mit reflektierenden Gegenständen im Laserstrahl arbeiten
- Armbanduhr, Schmuck und andere reflektierende Gegenstände ablegen.
- Beim Einsetzen optischer Bauteile den Laserstrahl an der Quelle abschalten oder geeignet abdecken, bis die Bauteile positioniert sind
- Teilweise wird mit unsichtbaren Laserstrahlen gearbeitet, deren Verlauf nicht sichtbar ist.
- Falls nötig, Laserschutzbrillen oder Laserjustierbrillen benutzen.

Die Firma LD Didactic GmbH haftet nicht für eine missbräuchliche Verwendung der Geräte durch den Kunden.

Der Kunde verpflichtet sich hiermit die Geräte nur entsprechend der rechtlichen Grenzen einzusetzen und insbesondere den Laserstrahl nicht im Straßenverkehr oder Luftraum zu verwenden oder in anderer Form auf Personen und Tiere zu richten.

Der Kunde bestätigt, das er befugt ist, diesen Laser zu erwerben und zu verwenden.

PHYSICS

CHEMISTRY  
BIOLOGY

ENGINEERING



## Laser Safety Notes

LD Didactic GmbH informs the customer this is laser equipment of either class 3A, 3B or 4 according to IEC 60 825. Typically a Nd:YAG Pump Diode is class 4, a HeNe with output coupler class 3A, but a HeNe with two high reflecting mirrors only class 1. Please see manual or attached labels for the exact specification of the laser.

Special safety precautions are necessary. Please check with local regulations. Typically the use requires a safety sign and a warning lamp that is on when the laser is activated and it might also be necessary to do and document a risk assessment.

Due to product liability, the laser must not be sold to individual persons. Companies, higher schools and universities might use it, but are notified that misuse of the laser poses a health risk, especially for the eyes.

The intended use of this equipment is for lessons, education and research in higher schools, universities or similar institutions.

Do not operate the devices outside parameters specified in the manual.

People using the laser must be properly trained and students must be supervised.

As a general guidance, the user is advised to:

- Check the laser for damages before use
- Not to look into the beam
- Take necessary measures that no people or animals can accidentally enter the beam area
- do not direct the beam on reflecting surfaces or into public areas
- do not work close to the light path with reflecting tools
- take off all jewelry and wristwatches when working with the laser to avoid reflections
- While placing or removing optical parts in the light path, switch off the laser or cover its exit
- Some of the experiments use invisible laser beams, but still might hurt the eye
- use laser protection glasses or laser adjustment glasses where necessary
- supervise students by trained personnel when they work with the laser system
- use the laser system only as described in the instruction manuals

Customer acknowledges the receipt of this information.

The customer indemnifies LD Didactic from liability for any damages that occur because of misuse of the laser.

The customer confirms that he will obey all local regulations and is allowed by law to buy and use the laser system.



# Table of Contents

<b>1.0 LASER DIODES</b>	<b>3</b>
1.1 <i>The energy band model</i>	3
1.1.1 The binding of the hydrogen molecule	3
1.1.1 Periodic potentials	5
1.1.2 Fermi distribution	5
1.2 <i>Semiconductors</i>	7
1.3 <i>Semiconductor laser</i>	9
1.4 <i>Resonator and beam guidance</i>	10
1.5 <i>Divergence and intensity distribution</i>	10
1.6 <i>Polarisation</i>	10
1.7 <i>Spectral properties</i>	10
1.8 <i>Optical power</i>	11
<b>2.0 DETECTORS, PROPERTIES</b>	<b>12</b>
2.1 <i>Ge and Si PIN-diodes</i>	13
<b>3.0 DIODE LASER AND ND:YAG</b>	<b>14</b>
<b>4.0 EXPERIMENT</b>	<b>16</b>
4.1 <i>Set-Up</i>	16
4.2 <i>Description of Modules</i>	16
4.3 <i>Spatial Beam Distribution</i>	18
4.4 <i>Wavelength Dependence</i>	19
4.5 <i>Wavelength Measurement with a Spectrum Analyser</i>	20
4.6 <i>Polarisation</i>	21
4.7 <i>Beam shaping</i>	22
4.8 <i>Digital Laser Diode Controller</i>	23
<b>5.0 LASER SAFETY</b>	<b>24</b>

## 1.0 Laser diodes

The laser diodes are a special class of lasers. They differ from „conventional“ lasers in two points:

1. For the classical lasers the laser-active atoms (molecules or ions) are independent of one another and only the same energy levels are used for the laser process. This means in principle that in order to produce a population inversion an infinite number of atoms can contribute (Boltzmann statistics).
2. This is not the case with semiconductor lasers. Here a defined energy level can only be occupied by two active particles (electrons, Pauli principle). But in semiconductors, the wave functions of the individual atoms overlap to form a common energy band and the extent to which the level is occupied follows the Fermi Dirac statistics. When considering the laser process, the transition between the distribution of population in two energy bands instead of two energy levels must be taken into account as for conventional lasers.

Laser diodes do not have any inherently defined emission wavelength, because there are no two discrete energy levels that are responsible for the laser process as with traditional lasers, but rather an energy distribution of electrons in energy bands. The second important difference concerns the propagation of the laser light within the pn zone. The spatial intensity distribution of the laser beam is defined by the laser medium and not by the resonator as for normal lasers. The goal of this experiment is also the understanding and checking of the basic facts. Therefore the difference between a laser with two discrete energy levels and the semiconductor laser with the typical band structure will be discussed in the following.

### 1.1 The energy band model

Atoms or molecules at large distance (compared to the spatial dimensions) to their neighbours do not notice mutually their existence. They can be considered as independent particles. Their energy levels are not influenced by the neighbouring particles.

The behaviour will be different when the atoms are approached as it is the case within a solid body. Depending on the type of atoms and their mutual interaction the energy states of the electrons can change in a way that they even can abandon „their“ nucleus and move nearly freely within the atomic structure. They are not completely free, otherwise they could leave the atomic structure.

How the „free“ electrons behave and how they are organised will be the subject of the following considerations. From the fundamentals of electrostatics we know that unequal charges attract. Therefore it is easy to imagine that an atomic structure is formed by electrostatic forces.

In the following we will call it „crystal“. However, this model will fail latest when we try to justify the existence of solid Argon just by freezing it sufficiently. Since there is obviously some sort of binding within the crystal structure in spite of the fact that inert gases are neutral there must be additional forces which are responsible for this binding.

To understand these forces we must call on quantum mechanics for help. At the beginning this may be a bit difficult but it simplifies the later understanding. The Hamilton operator and Schroedinger's equation are supposed to be known. But the acceptance of the result of the following expertise on exchange interaction, exchange energy and tunnel effect for the formation of energy bands will be sufficient for further understanding provided quantum mechanics is considered as the background of all.

#### 1.1.1 The binding of the hydrogen molecule

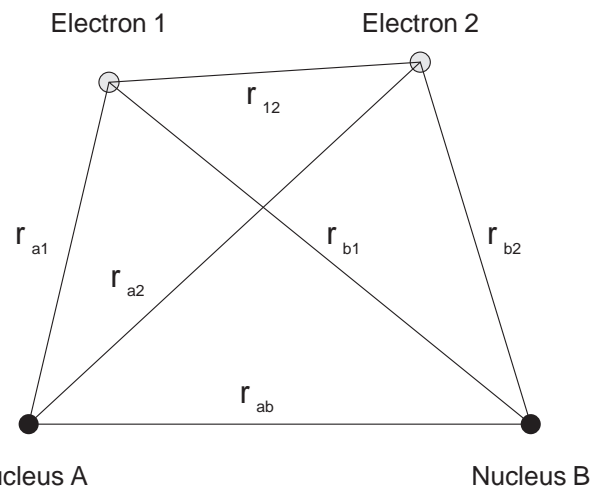

Fig. 1: Interaction of two hydrogen molecules

The total electric potential energy is:

$$U = -e^2 \cdot \left( \frac{1}{r_{a1}} + \frac{1}{r_{b2}} + \frac{1}{r_{b1}} + \frac{1}{r_{a2}} - \frac{1}{r_{ab}} \right) \quad (1.1.1)$$

The following Schroedinger equation has to be solved:

$$\Delta\Psi_1 + \Delta\Psi_2 + 8\pi^2 \frac{m}{h^2} \cdot (E - U) \cdot \Psi = 0$$

For two hydrogen atoms without interaction the total energy will be

$$E = E_0(1) + E_0(2) = 2E_0$$

Correspondingly the eigenfunction  $\Psi$  is the product of the eigenfunctions of the individual electrons belonging to the nuclei a and b.

$$\Psi_{12} = \Psi_a(1) \cdot \Psi_b(2)$$

Since we can not distinguish between the individual electrons also the following linear combinations are valid eigenfunctions:

$$\Psi_{anti} = \Psi_a(1) \cdot \Psi_b(2) + \Psi_a(2) \cdot \Psi_b(1)$$

$$\Psi_{sym} = \Psi_a(1) \cdot \Psi_b(2) - \Psi_a(2) \cdot \Psi_b(1)$$

At the same time Pauli's principle has to be respected, that means the eigenfunction  $\Psi_{anti}$  contains additionally the antiparallel spins ( $\uparrow\downarrow + \downarrow\uparrow$ ) and the function  $\Psi_{sym}$  the parallel spins ( $\uparrow\uparrow - \downarrow\downarrow$ ). The electron distribution described by the linear combinations depends also on the distance dependent mutual electrostatic disturbance. As disturbance we have to consider the terms



$$\Delta U = -e^2 \cdot \left( \frac{1}{r_{b1}} + \frac{1}{r_{a2}} - \frac{1}{r_{ab}} \right)$$

which are the reason for the mutual interaction. To get the complete solution we have to add a „disturbance“-term to the undisturbed eigenfunctions  $\psi_a$  and  $\psi_b$ , as well as to the undisturbed energy. Then Schrodinger's equation will no more be homogenous but inhomogeneous because of the additional „disturbance“-term. As solution we get:

$$E_{sym} = 2E_0 + e^2 \cdot C + e^2 \cdot A$$

$$E_{anti} = 2E_0 + e^2 \cdot C - e^2 \cdot A$$

We see that a term with the constant C representing the Coulomb part and a term with the constant A representing the interaction are added to the undisturbed energy. The exchange energy is based on the fact that electron 1 is localised near to nucleus A at a particular instant and near to nucleus B at another instant. The sign of A can be positive or negative. The energy difference between the two possible energies is just

$$\Delta E = E_{sym} - E_{anti} = 2 \cdot e^2 \cdot A$$

A detailed calculation results in the following relation for C:

$$C = \iint \left( \frac{1}{r_{ab}} - \frac{1}{r_{a2}} - \frac{1}{r_{b1}} + \frac{1}{r_{12}} \right) \cdot \Psi_a^2(1) \cdot \Psi_b^2(2) d^3r$$

and for A:

$$A = \iint \left( \frac{1}{r_{ab}} - \frac{1}{r_{a2}} - \frac{1}{r_{b1}} + \frac{1}{r_{12}} \right) \cdot \Psi_a(1) \Psi_b(2) \Psi_a(2) \Psi_b(1) \cdot d^3r$$

Under respect of the fact that  $\psi_{a2}(1)$  and  $\psi_{b2}(2)$ , integrated over the whole space represent probability densities which, multiplied by the elementary charge e, provide the total charge density  $\rho$  of the electrons 1 or 2 near the nuclei A or B, the constant C can also be written as:

$$e^2 C = \frac{e^2}{r_{ab}} - \int \frac{e^2 \rho_1}{r_{b1}} d^3r_1 - \int \frac{e^2 \rho_2}{r_{a2}} d^3r_2 + \iint \frac{e^2 \rho_1 \rho_2}{r_{12}} d^3r_1 d^3r_2$$

We see that C results out of the attracting or repulsing Coulomb forces. The exchange integral A looks very much like the Coulomb integral. But the electron densities  $\psi_{a2}(1)$  resp.  $\psi_{b2}(2)$  have been replaced by the mixed terms  $\psi_a(1) \psi_b(2)$  and  $\psi_a(2) \psi_b(1)$  which are the result of the electron exchange. Here we can summarise as follows: If atoms are mutually approached the states of the undisturbed energy levels split into energetically different states. The number of newly created energy states are corresponding to the number of exchangeable electrons. (Fig. 20).

One of the curves shows a minimum for a particular distance of the atoms. No doubt, without being forced the atoms will approach till they have acquired the minimum of potential energy. This is also the reason for hydrogen to occur always as molecular hydrogen  $H_2$  under normal conditions. The second curve does not have such a distinct property. The curves distinguish in so far as for the

binding case the spins of the electrons are anti-parallel. For the non-binding case they are parallel. It is easy to imagine that an increase of the number of atoms also increases the number of exchangeable electrons and in consequence also the number of newly generated energy levels. Finally the number of energy levels is so high and so dense that we can speak about an energy band. Here it is interesting to compare the action of the electrons with the behaviour of ambassadors.

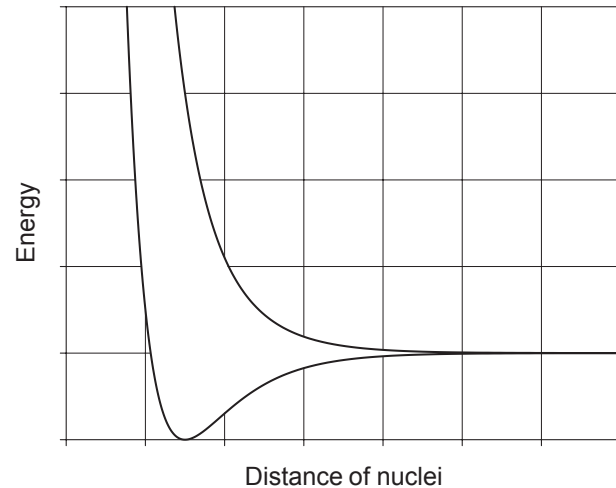

Fig. 2: Potential energy due to interaction of two hydrogen atoms

The electrons in the most outside shell will learn first about the approach of an unknown atom. The eigenfunctions will overlap in a meaningful way. One electron will leave the nucleus tentatively to enter an orbit of the approaching atom. It may execute a few rotations and then return to its original nucleus.

If everything is OK and the spins of the other electrons have adapted appropriate orientations new visits are performed. Due to the visits of these „curious“ electrons the nuclei can continue their approach. This procedure goes on till the nuclei have reached their minimum of acceptable distance. Meanwhile it can no more be distinguished which electron was part of which nucleus.

If there is a great number of nuclei which have approached in this way there will also be a great number of electrons which are weakly bound to the nuclei. Still, there is one iron-rule for the electrons: my energy level can only be shared by one electron with opposite spin (Pauli principle). Serious physicists may now warn to assume that there may be eventually male and female electrons. But who knows.....

Let's return to incorruptible physics.

Up to now we presumed that the atom only has one electron. With regard to the semiconductors to be discussed later this will not be the case. Discussing the properties of solid bodies it is sufficient to consider the valence electrons that means the most outside located electrons only as it has been done for separated atoms. The inner electrons bound closely to the nucleus participate with a rather small probability in the exchange processes. Analogously to the valence electrons of the atoms there is the valence band in solid bodies. Its population by electrons defines essen-

tially the properties of the solid body. If the valence band is not completely occupied it will be responsible for the conductivity of electrons. A valence band not completely occupied is called **conduction band**.

If it is completely occupied the next not completely occupied band will be called conduction band.

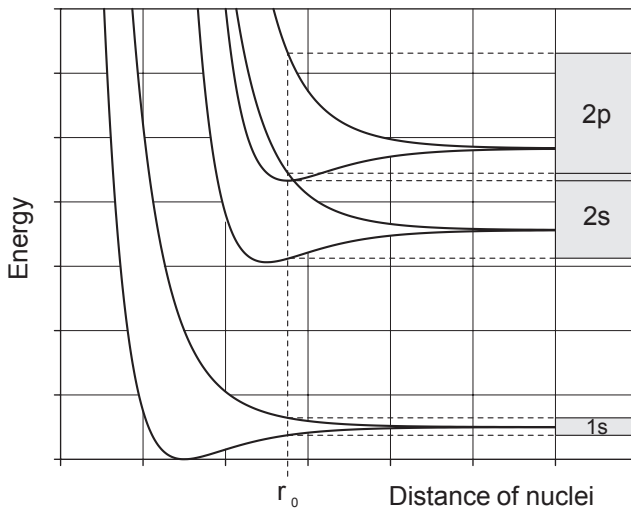

**Fig. 3: Band formation by several electrons. The most outside electrons are responsible for the equilibrium distance  $r_0$ .**

In the following section the question is to be answered how the density of states of a band of electrons looks like and on which quantities it depends. Before doing that and for reasons of completeness another attempt is made to determine the electron distribution within a solid body.

### 1.1.1 Periodic potentials

Although quantum mechanics is fairly powerful, up to now one has not succeeded to calculate the energy eigenvalues of complex atoms and molecules. One generally relies on skilful statements for the energy potentials to which the electrons are submitted. The statement of periodical potentials has been found to be especially powerful.

### 1.1.2 Fermi distribution

In Fig. 3 we have shown that the energy bands are the result of the mutual interaction of the atoms. Each band has a particular width  $\Delta E$ , the magnitude of which is determined by the exchange energy and not by the number  $N$  of the interacting atoms. Furthermore we know that the number of energy levels within a band is determined by the number of interacting electrons. The Pauli principle states that such a level can only be occupied by two electrons. In this case the spins of the electrons are antiparallel. Within a band the electrons are free to move and they have a kinetic energy of

$$E = \frac{1}{2}mv^2 \quad \text{or} \quad E = \frac{p^2}{2m}$$

The mass of the electron is  $m$ ,  $v$  the velocity and  $p$  the impulse. The constant potential energy will not be taken into consideration. Furthermore we will set the energy of the lower band edge to zero. The maximum energy  $E_{\max}$  of an electron within a band can not pass the value  $\Delta E$  since otherwise the electron would leave the band and no longer

be a part of it. Consequently we can write:

$$E_{\max} = \Delta E = \frac{1}{2m} p_{\max}^2$$

We still have to find out how many electrons of energy  $E \leq E_{\max}$  exist and within a second step we wish to know how many electrons exist in the energy interval  $dE$ . To reach this goal we will use a trick already applied in deriving the number of modes in a cavity resonator (see also EXP01 Emission & Absorption). But here we will consider electrons instead of photons. The course of considerations will be the same since we can attribute to each electron a wave with wave vector  $k$ . For the impulse  $p$  we write:

$$\vec{p} = \hbar \cdot \vec{k}$$

Only such electron energies are permitted within a volume the wave functions of which are zero at the walls. To express it in a more simple way: an integer multiple of half the wavelength  $\lambda$  of the associated standing wave must fit, for instance, into the length  $L$  of a cube:

$$L_x = n_x \frac{\lambda}{2} \quad \text{and} \quad k_x = \frac{2\pi}{\lambda}$$

For the electron energy of the cube we get:

$$E = \frac{p^2}{2m} = \frac{\hbar^2}{2m} \vec{k} \cdot \vec{k} = \frac{\hbar^2}{2m} (k_x^2 + k_y^2 + k_z^2)$$

$$E = \frac{2\hbar^2}{m} \left( \frac{n_x^2}{L_x^2} + \frac{n_y^2}{L_y^2} + \frac{n_z^2}{L_z^2} \right) = \frac{2\hbar^2}{mL^2} (n_x^2 + n_y^2 + n_z^2)$$

Let's remember the equation of a sphere

$$R^2 = x^2 + y^2 + z^2$$

and compare it with the equation for  $E$ . We recognise an analogous equation of the following type:

$$E \frac{mL^2}{2\hbar^2} = (n_x^2 + n_y^2 + n_z^2)$$

$$E = \frac{\hbar^2 k^2}{2m}$$

or with

$$L^2 \frac{k^2}{\pi^2} = n_x^2 + n_y^2 + n_z^2$$

The radius of this sphere is  $Lk/\pi$  and  $n_1, n_2, n_3$  are the  $x, y, z$  coordinates. As  $n$  is an integer and positive they only generate one eighth of a complete sphere set up by a spatial lattice with lattice constant 1.

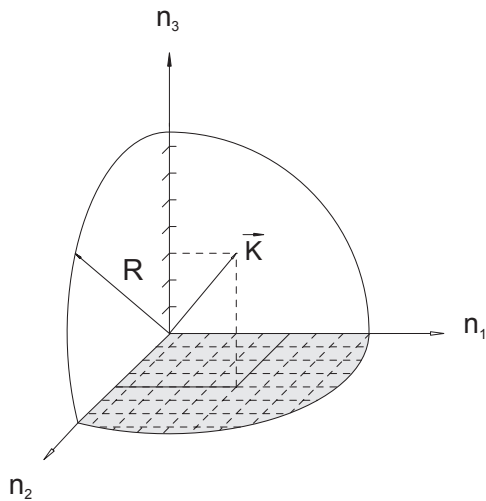

Fig. 4: Calculation of the electron density

Permissible are only such wave vectors  $\vec{k}$ , the components of which are coinciding with the  $n$  values or, to express it differently, each point of intersection of the lattice represents a valid solution for the wave vector  $k$  of a stationary wave. The answer to the initially raised question regarding the number of electrons for a particular length  $L$  of a potential box results now out of the counting of the number of points of intersection (Fig. 4).

This work can also be done analytically. If one uses the formula for the volume of a sphere  $V_{\text{sphere}} = 4/3 \pi R^3$  one gets for one eighth of a sphere with a radius for an upper limit of energy at  $E_{\text{max}}$ :

$$N(E_{\text{max}}) = \frac{1}{8} \cdot \frac{4}{3} \pi \cdot \left( L \frac{k}{\pi} \right)^3$$

with  $E = \frac{\hbar^2 k^2}{2m}$  or  $k^2 = \frac{4\pi^2}{h^2} 2mE$  one gets:

$$N(E) = \frac{8}{3} \frac{\pi}{h^3} V \cdot (2mE)^{3/2}$$

Here  $V$  is the volume of the box. An additional factor of 2 accounts for the fact that two electrons are admitted in each state if their spins are antiparallel. Let's divide  $N(E)$  by the volume  $V$  to get the electron density

$$n(E) = \frac{8}{3} \frac{\pi}{h^3} \cdot (2mE)^{3/2}$$

The electron density per unit energy  $dn(E)/dE$  is found by differentiation:

$$dn(E) = \frac{4\pi}{h^3} (2m)^{3/2} \sqrt{E} \cdot dE$$

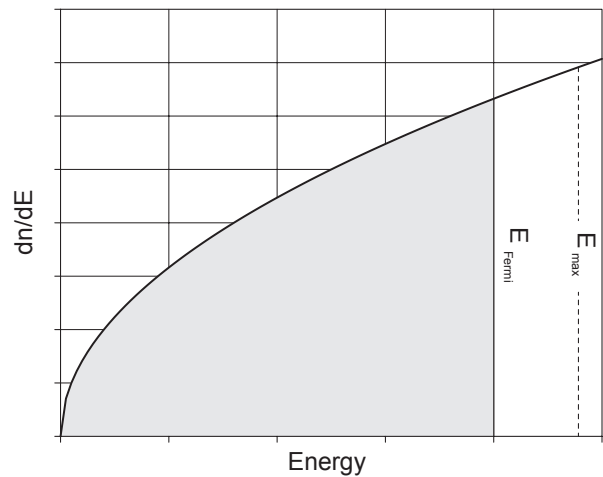

Fig. 5: Number of electrons per unit volume  $V$  and energy interval  $dE$  as a function of the energy  $E$ .

The situation in Fig. 5 shows that the band has not been completely filled up since the Fermi energy is smaller than the maximal possible energy. This means that this band is a conduction band. If the Fermi energy would be equal to the maximal energy we would have a valence band. A transfer of this knowledge to the energy level scheme of Fig. 3 and a selection of the 2s band would provide the picture of Fig. 6. Up to this point we anticipated that the temperature of the solid body would be 0 K. For temperatures deviating from this temperature we still have to respect thermodynamic aspects namely additional energy because of heat introduced from outside. Fermi and Dirac described this situation using statistical methods. The electrons were treated as particles of a gas: equal and indistinguishable. Furthermore it was presumed that the particles obey the exclusiveness principle which means that any two particles cannot be in the same dynamic state and that the wave function of the whole system is antisymmetrical.

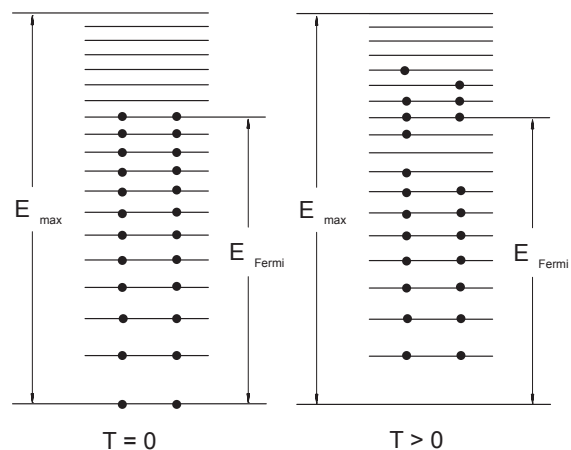
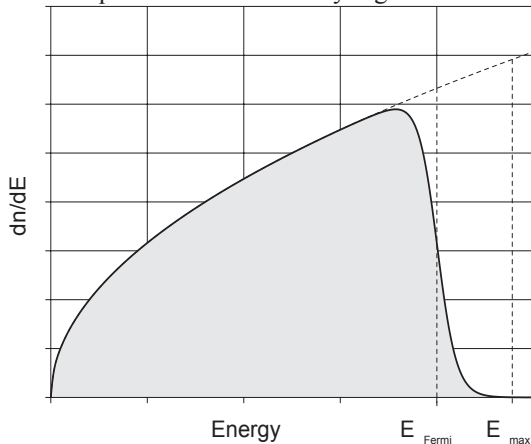

Fig. 6: Distribution of free electrons over the energy states within a conduction band

Particles which satisfy these requirements are also called Fermions. Correspondingly all particles which have a spin of  $1/2$  are Fermions and obey the Fermi Dirac statistics. Electrons are such particles. Under respect of these assumptions both physicists got the following equation for the particle density of the electrons within an energy interval  $dE$ :

$$\frac{dn(E)}{dE} = \frac{4\pi}{h^3} (2m)^{3/2} \cdot \frac{\sqrt{E}}{e^{\frac{E-E_{Fermi}}{kT}} + 1} \cdot dE$$

The above equation is illustrated by Fig. 7.

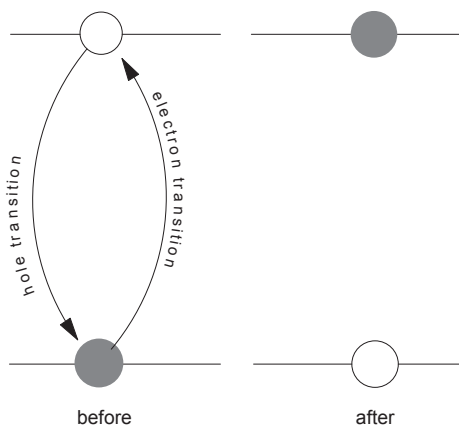

**Fig. 7: Number of electrons per unit volume and energy interval dE as a function of the energy E, but for a temperature T > 0.**

As shown in Fig. 6 by introduction of thermal energy the „highest“ electrons can populate the states which are above them. Based on these facts we are well equipped to understand the behaviour of solid bodies. We are going to concentrate now our special interest on the semiconductors which will be presented in the next chapter with the help of the previously performed considerations.

### 1.2 Semiconductors

Before starting the description of the semiconductor with regard to its behaviour as „lasing“ medium we still have to study the „holes“. States of a band which are not occupied by electrons are called „holes“. Whenever an electron leaves its state it creates a hole. The electron destroys a hole whenever it occupies a new state. The whole process can be interpreted in that way that the hole and the electron exchange their position (Fig. 7). Also the holes have their own dynamic behaviour and can be considered as particles like the electrons. It is interesting to note that the holes do have the exact opposite properties of the electrons. Since the temporary course of the holes' migration is the same as for the electron they have also the same mass except that the mass of the hole has the opposite sign. Furthermore its charge is positive.



**Fig. 8: Electron and hole transition**

Once the existence of the holes has been accepted they also have to have a population density. It will be introduced in the following. For this reason we complete Fig. 6 as shown in Fig. 9.

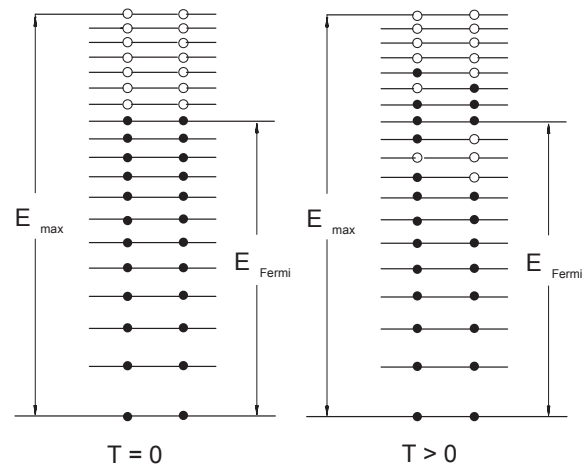

**Fig. 9: Distribution of the holes and the electrons within an energy band**

It is easy to understand that on one side the holes are preferably at the upper band edge and on the other side their population density results out of the difference of the population density minus the population density of the electrons. Fig. 10 shows the population density of the electrons. Fig. 11 shows the difference and in so far the population density of the holes. Attention has to be paid to the fact that the abscissa represents the energy scale of the band and not the energy of the holes.

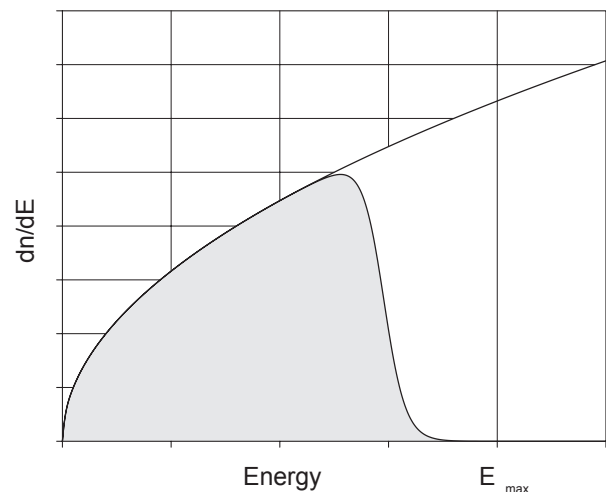

**Fig. 10: Population density of the electrons**

To prepare the discussion of optical transitions in semiconductors it gives a sense to modify the diagrams. Until now the abscissa was used as energy scale for the diagrams of the state and population densities. For the presentation of optical transitions it is more practical to use the ordinate as energy scale. To get use to it Fig. 10 has been represented in the modified way in Fig. 12. The shown population density refers to an energy scale for which the lower edge of the valence band has been set arbitrarily to zero. The represented situation refers to a semiconductor where the distance between conduction and valence band is in the order of magnitude of thermal energy (kT). Here the Fermi energy lies in the forbidden zone.

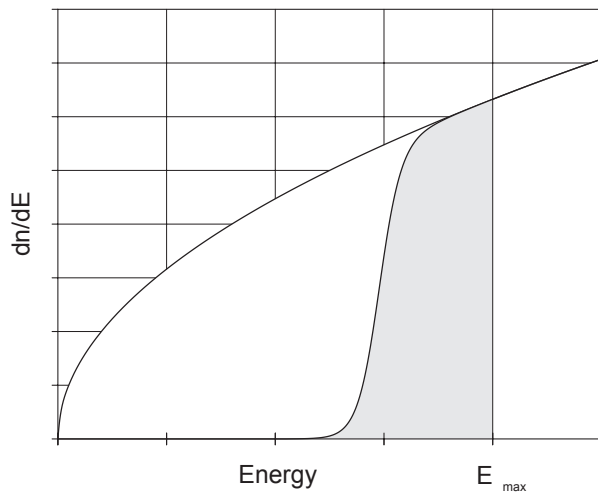

**Fig. 11: Population density of the holes**

Because of the thermal energy some electrons have left the valence band and created holes. For the following considerations it is sufficient to learn something about the population densities of the electrons in the conduction band as well as about the holes in the valence band. As will be shown later there are optical transitions from the conduction band to the valence band provided they are allowed. Near the lower band edge of the conduction band the state densities are admitted to be parabolic. The same is true for the holes at the upper edge of the valence band (Fig. 13). The densities of states inform about the number of states which are disposed for population and the spectral distribution reflects how the electrons and holes are distributing over these states. Next to the band edges the spectral distribution fits to a Boltzmann distribution.

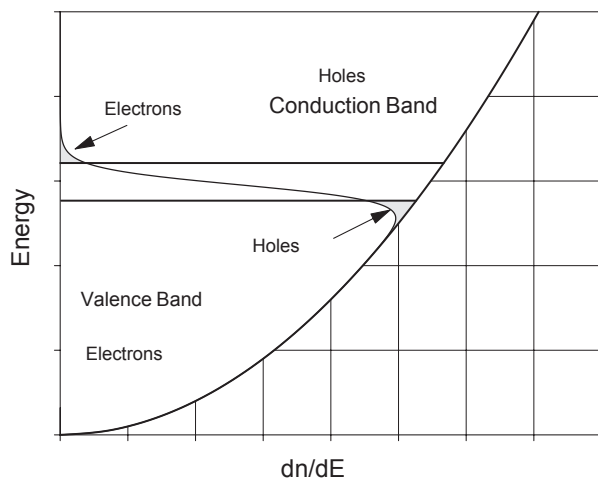

**Fig. 12: Population density on the energy scale**

If we succeed to populate the conduction band with electrons and to have a valence band which is not completely occupied by electrons (Fig. 13) electrons may pass from the conduction band to the valence band. That way a photon is generated. By absorption of a photon the inverse process is also possible.

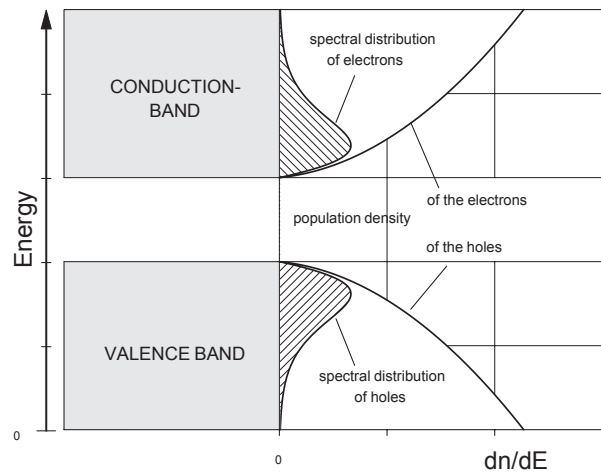

**Fig. 13: Densities of states and spectral distributions**

The following illustration Fig. 14 shows the situation of a population inversion in a semiconductor. Attention must be drawn to the fact that, until now, we only discussed a semiconductor consisting of one type of atoms. Consequently the situation shown in Fig. 14 is, at least for this type of direct semiconductor, only fictitious. It can only be created for very short intervals of time and can therefore not be taken into consideration for the realisation of a semiconductor laser. By doping the basic semiconductor material we can create band structures with different properties.

A very simple example may be the semiconductor diode where the basic material, germanium or silicon, is converted into p or n conducting material using suitable donors and acceptors. By the connection of the doped materials a barrier (also called active zone) is formed. It will be responsible for the properties of the element. Silicon is mainly used for highly integrated electronic circuits while ZnS is chosen as fluorescent semiconductor for TV screens.

As light emitting diodes and laser diodes so called mixed semiconductors like AlGaAs are in use. Mixed semiconductors can be obtained whenever within the semiconductors of valence three or five individual atoms are replaced by others of the same group of the periodical system. The most important mixed semiconductor is aluminum gallium arsenide (AlGaAs), where a portion of the gallium atoms has been replaced by aluminum atoms. This type of semiconductor can only be produced by a fall out as thin crystal layer, the so called epitaxy layer, on host crystals. To perform this stressfree it is important that the lattice structure of the host crystal (lattice matching) coincides fairly well with the lattices structure of AlGaAs.

This is the case for GaAs substrate crystals of any concentration regarding the Al and Ga atoms within the epitaxy layer. In that way the combination of AlGaAs epitaxy layers and GaAs substrates offers an ideal possibility to influence the position of the band edges and the properties of the transitions by variation of the portions of Ga or Al.

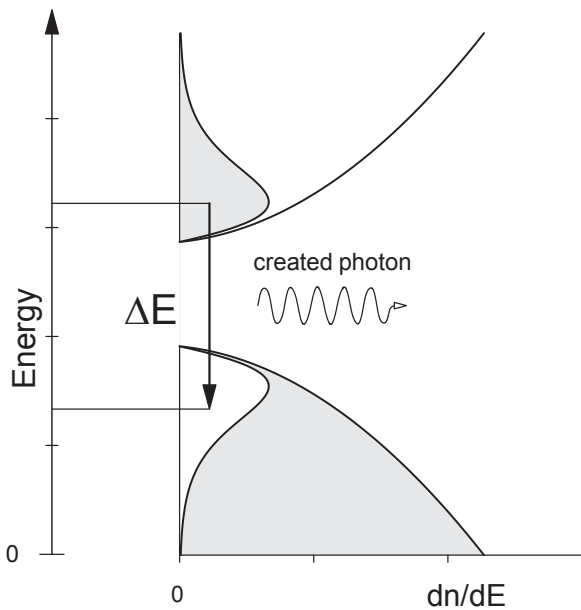

Fig. 14: Population inversion in a semiconductor for  $T > 0$

### 1.3 Semiconductor laser

As simple as it may seem, it took about 20 years until people had acquired the necessary technology of coating under extremely pure conditions. It all began in 1962 with the first laser diode, just two years after Maiman had demonstrated the first functional ruby laser. In the course of 1962 three different groups reported more or less simultaneously the realisation of GaAs diode lasers.

1. R. N. Hall      General Electric
2. M. I. Nathan    IBM
3. T. M. Quist     MIT

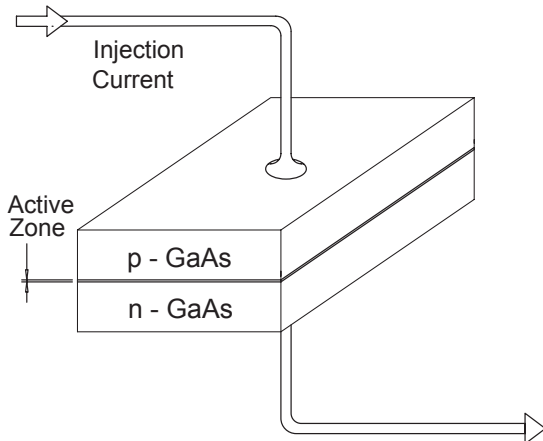

Fig. 15: Simple laser diode around 1962, working at 70 K and with 100 kA/cm<sup>2</sup> in the pulse mode.

The first laser was basically made of highly doped GaAs (Fig. 15). A threshold current of 100 kA/cm<sup>2</sup> was needed since the GaAs material of those days was not by far as good as it is today regarding the losses within the crystal. Because of thermal conditions the laser could only work at 70 °K and in the pulsed mode. In the course of the following years the threshold could be lowered to 60 kA/cm<sup>2</sup> by improving the crystals but only the use of a hetero-transition (Bell Labs. and RCA-Labs.) brought the „break-through“ in 1968. The threshold could be lowered to 8 kA/cm<sup>2</sup> and working in the pulse mode at room temperature

was possible (Fig. 16).

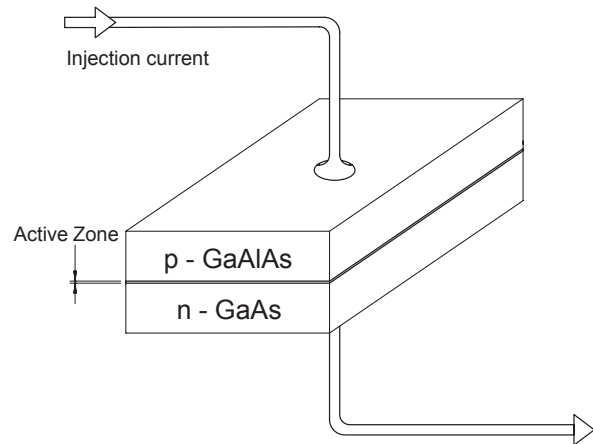

Fig. 16: Simple-heterostructured laser around 1968, working at 8 kA/cm<sup>2</sup> in pulse mode at room temperature.

In this concept a layer of p conducting GaAlAs is brought on the p layer of the pn transition of GaAs. The slightly higher band gap of GaAlAs compared to GaAs ensures that a potential barrier is created between both materials in a way that charge carriers accumulate here and the formation of inversion is increased respectively the laser threshold is remarkably lowered to 8 kA/cm<sup>2</sup>.

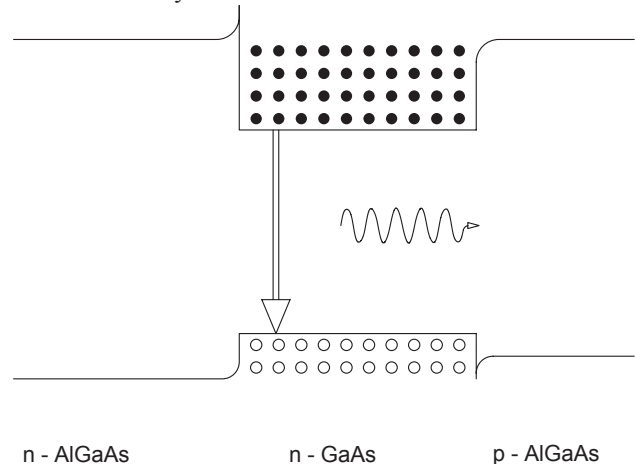

Fig. 17: Energy band diagram of a N n P - double hetero structure.

The next step in development was the attachment of a similar layer on the n-side of the crystal. That way the threshold could be lowered once again in 1970. Now it amounted to about 1 kA/cm<sup>2</sup>. Until today nearly all commercially sold laser diodes are built up on the double hetero structure principle (Fig.18 and Fig. 19).

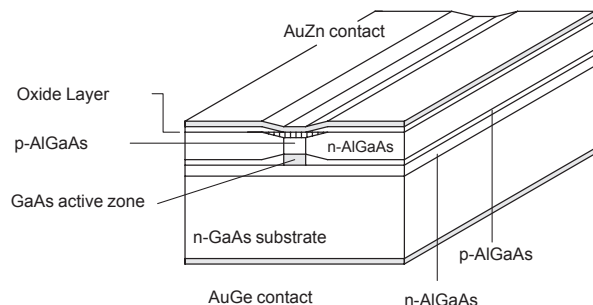

Fig. 18: „Buried“ hetero structure. The active zone has been buried between some layers which ensure an optimal beam guidance in the zone.

### 1.4 Resonator and beam guidance

As already mentioned at the beginning the diode laser differs from the „classical“ lasers in the dimensions of the resonator and in the propagation of the beam. For the diode lasers the active material represents the resonator at the same time. Furthermore the ratio of the resonator length ( 300  $\mu\text{m}$  ) to the wavelength (820 nm) is:

$$L / \lambda = 366 ,$$

For a HeNe-Laser (  $\lambda = 632 \text{ nm}$  ) with a typical resonator length of 20 cm this ratio is 3 108. Considering additionally the lateral dimensions of the resonator we get a ratio of 12.5 for the diode lasers with a typical width of 10  $\mu\text{m}$  for the active zone. With capillary diameters of the He-Ne tubes of about 1 mm one gets a value of 1582. This already indicates that the beam characteristics of the laser diode will distinguish significantly from „classical“ lasers.

### 1.5 Divergence and intensity distribution

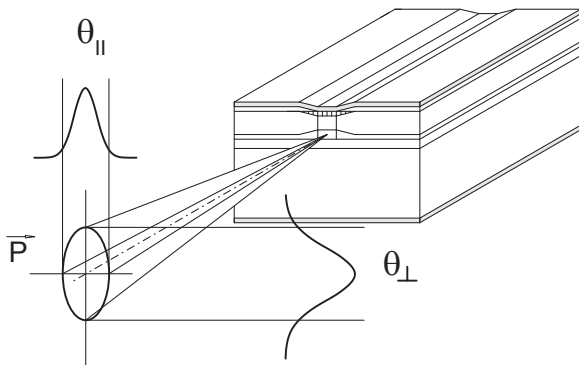

Fig. 19: Elliptical beam profile of a diffraction limited laser diode in the far field (some meters).

Not only the beam guidance but also the size of the laser mirrors influences the beam geometry. Generally for conventional lasers the mirrors are very large compared with the beam diameter. The laser mirror ( crystal gap area of the active zone) of the laser diodes has a size of about 10  $\mu\text{m}$  x 2  $\mu\text{m}$ , through which the laser beam has „to squeeze“ itself. Diffraction effects will be the consequence and lead to elliptical beam profiles (Fig. 19).

The polarisation is parallel to the "junction plane", that is the plane which is passed by the injection current perpendicularly. The divergence angles  $\theta_{\perp}$  and  $\theta_{\parallel}$  differ by about 10-30° depending on the type of laser diode.

If the beams are extended geometrically into the active medium the horizontal beams will have another apparent point of origin as the vertical beams. The difference between the points of origin is called astigmatic difference (Fig. 20). It amounts to about 10  $\mu\text{m}$  for the so called index guided diodes. For the so called gain guided diodes these values are appreciably higher.

Modern diodes are mostly index guided diodes. This means that the laser beam is forced not to leave the resonator laterally by attaching lateral layers of higher refractive index to the active zone. At the gain guided diodes the

current is forced to pass along a small path (about 2-3  $\mu\text{m}$  width).

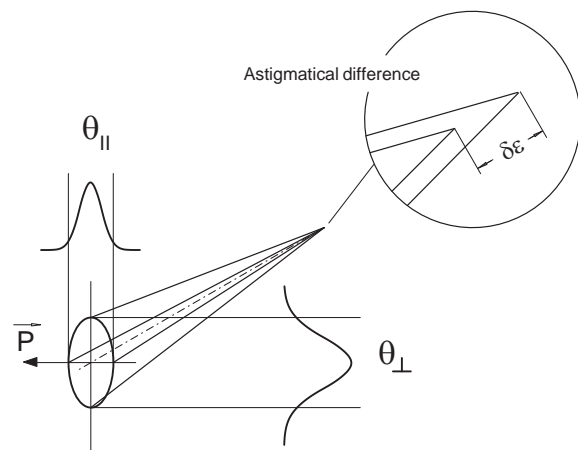

Fig. 20: Astigmatic difference  $\delta\epsilon$

In this way the direction of the amplification (which is proportional to the current flux) and the laser radiation are determined.

At the gain guided diodes the formation of curved wave fronts within the resonator is disadvantageous since they simulate spherical mirrors. In this case higher injection currents provoke transversal modes which will not appear in index guided diodes because of the plane wave fronts. Laser diodes with intensity profiles following a Gauss curve and a beam profile which is only limited by diffraction are called **Diffraction Limited Lasers** ( DFL ).

They represent the most „civilised“ diode lasers. For the time being they are only available for powers up to 200 mW. High power diode lasers as used, for example, to pump Nd YAG lasers partially have very fissured nearly rectangular intensity profiles.

### 1.6 Polarisation

It is understandable that the laser radiation of the diodes has a distinct direction of polarisation, since the height of the exit window is 4 times and the width 12.5 times larger than the wavelength.

Because of the fraction of spontaneous emission the light of the laser diode also contains components oscillating in the vertical direction

The ratio of polarisation,  $P_{\perp}$  to  $P_{\parallel}$  , depends on the output power since for higher laser power the ratio of spontaneous to stimulated emission is changing (Fig. 22).

### 1.7 Spectral properties

Another property of the diode laser is the dependence of its wavelength on the temperature (about 0.25 nm/°K) and on the injection current (about 0.05 nm/mA).

Users who need a well defined wavelength have to adjust temperature and injection current in a way that the wavelength remains constant. By changing the temperature the wavelength of the laser radiation can be altered.

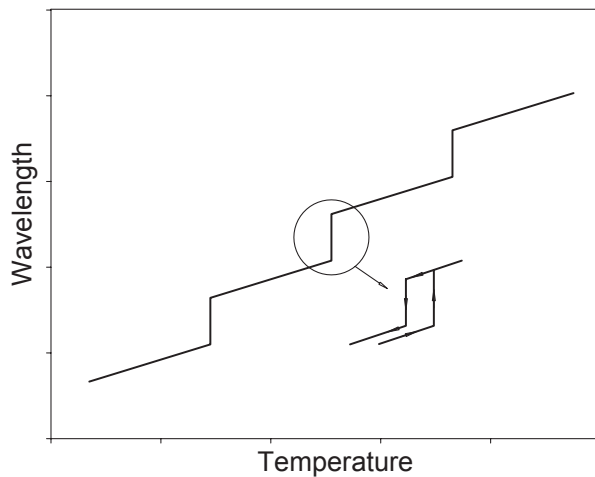

**Fig. 21: Emission wavelength as a function of the crystal temperature of the laser diode and hysteresis.**

The wavelength increases with increasing temperature. The reason for this is that the refractive index and the length of the active zone, respectively the resonator, increase with increasing temperature. Beyond a certain temperature the mode does not fit anymore into the resonator and another mode which faces more favourable conditions will start to oscillate. As the distance between two successive modes is very large for the extremely short resonator ( typical 300 μm ), the jump is about 0.3 nm. Lowering the temperature gets the laser jumping back in his wavelength. After this the laser must not be necessarily in the departing mode. Applications anticipating the tuning ability of the laser diode should therefore be performed within a jump-free range of the characteristic line (Fig.21).

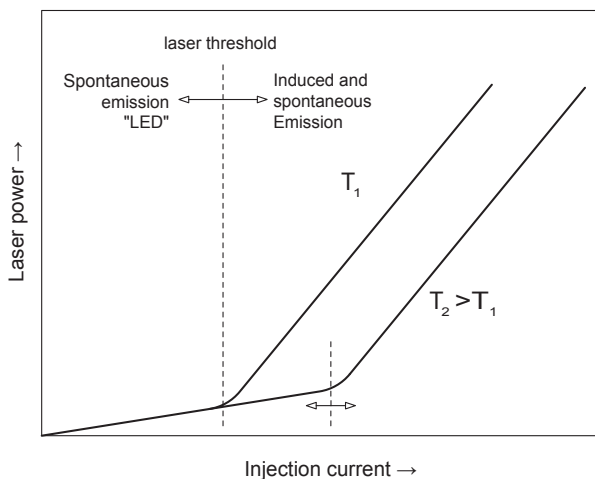

**Fig. 22: Laser power versus injection current with the temperature T as parameter**

A similar behaviour is observed for the variation of the injection current and in consequence for the laser output power. Here the change in wavelength is mainly the result of an increase in the refractive index which again is influenced by the higher charge density in the active zone. A higher output power provokes also a higher loss of heat and an increase in temperature of the active zone. The strong dependence of the current and the output power on the temperature are typical for a semiconductor (Fig. 40). The wavelength of the laser diode depends on the temperature T and the injection current I in the following way:

$$\lambda(T, I) = \lambda(T_0, I_0) + \alpha_T(T - T_0) + \alpha_I(I - I_0) + \alpha_T^2(T - T_0)^2 + \alpha_I^2(I - I_0)^2 + \dots + \alpha_T^n(T - T_0)^n + \alpha_I^n(I - I_0)^n$$

$\lambda(T_0, I_0)$  is a known wavelength at  $T_0$  and  $I_0$ .

Generally it is sufficient to consider only the linear terms. For a precision of  $\delta\lambda/\lambda < 10^{-6}$  the quadratic terms have to be respected. The equation is valid within a jump-free range. The requirement  $\lambda(\ddot{u}\ddot{u}) = \lambda_c$  provides directly:

$$I = \frac{(\lambda_c - \lambda_0)}{\alpha_I} - \frac{\alpha_T}{\alpha_I}(T - T_0)$$

One gets a dependence as shown in Fig. 23

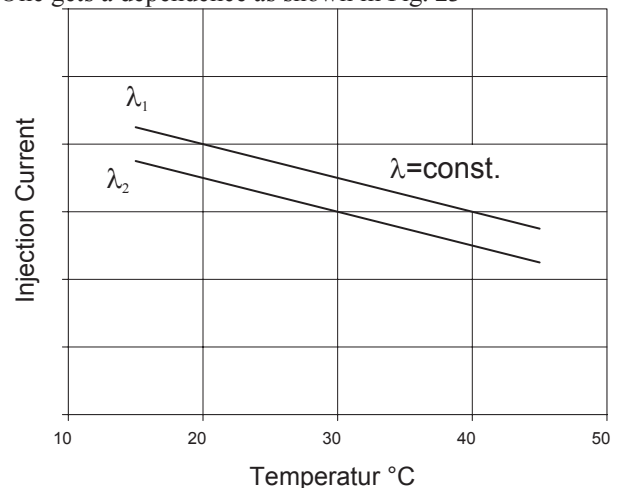

**Fig. 23: Injection current as a function of the temperature for constant wavelength**

### 1.8 Optical power

In regard to „classical“ lasers the light of a diode laser contains a remarkable high fraction of non-coherent „LED“ radiation. For currents underneath the laser threshold the spontaneous emission is dominant. Stimulated emission is responsible for the strong increase above the laser threshold. The threshold current can be determined by the point of intersection of the extrapolated characteristic lines of the initial and of the lasing working mode. The rounding off of the characteristic line is the result of spontaneous emission. It also is the cause for the oscillation of several modes next to the threshold. At higher currents the mode spectrum becomes more and more clean.



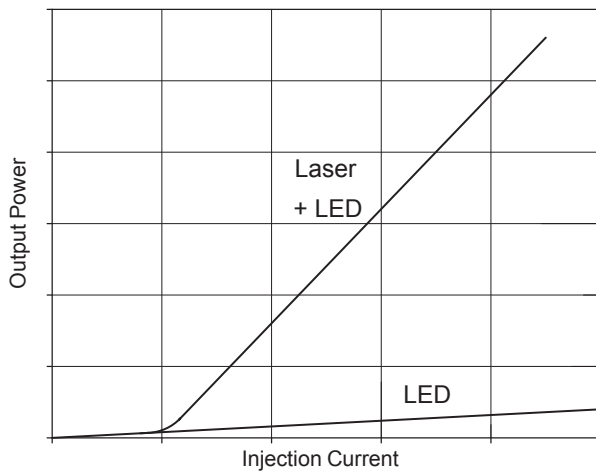

Fig. 24: Output power of the laser diode as a function of the injection current

## 2.0 Detectors, properties

Semiconductor pn-transitions with a band gap of  $E_g$  are suitable for the detection of optical radiation if the energy  $E_p$  of the photons is equal or greater than the band gap.

$$E_p = \hbar\omega \geq E_g$$

In this case an arriving photon can stimulate an electron to pass from the valence band to the conduction band. (Fig. 43).

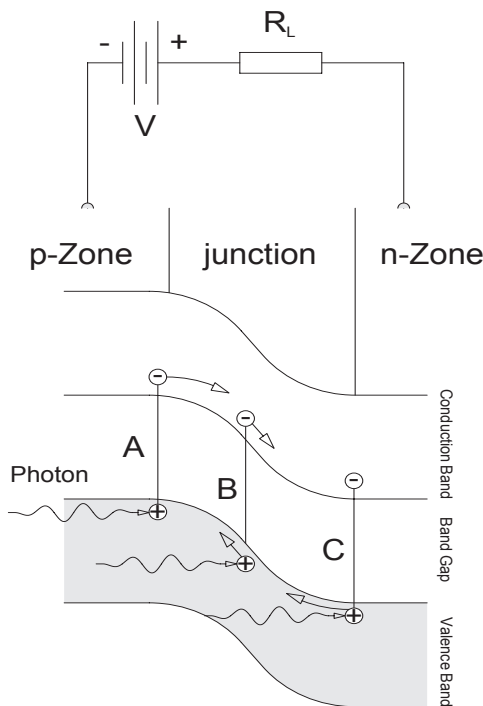

Fig. 25: Absorption of a photon with subsequent transition of the stimulated electron from the valence band to the conduction band

Here three types of events are possible:

**A.** An electron of the valence band in the p-zone is stimulated and enters the p-zone of the conduction band. Because of the external electric field due to the voltage  $V$  it will diffuse through the barrier layer into the n-zone and contributes to the external current passing the resistor  $R_L$  unless it recombines in the p-zone.

**B.** If an electron of the barrier layer is hit by a photon the hole of the barrier layer will migrate into the p-zone and the electron into the n-zone. The drift of both charges through the barrier layer causes a current impulse. The duration of the impulse depends on the drift speed and on the length of the barrier layer.

**C.** The case is similar to case A. The hole migrates due to the presence of the external field into the p-zone or recombines in the n-zone.

Only electrons which are in the barrier layer (case B) or near the boundary of the barrier layer (area of diffusion, case A and C) contribute to the external current due to stimulation by photons. All others will recombine within their area. In the utmost case one elementary charge  $q$  can be created for each incoming photon. As already mentioned, not every photon will create in the average a current impulse. In this context the production rate  $G$ , leading to an average current  $\langle i_{ph} \rangle$  is defined as follows:

$$\langle i_{ph} \rangle = q \cdot G$$

At a light energy of  $P_0$  a number of  $\frac{P_0}{\hbar\omega}$  photons will hit

the detector as  $\hbar\omega$  is just the energy of one photon. But only that fraction of photons is converted into current pulses which is absorbed in the barrier layer. This frac-

tion may be called  $\eta \cdot P_0$ , where  $\eta$  is called quantum efficiency. The number of generated current pulses or the production rate will be

$$G = \frac{\eta}{\hbar\omega} \cdot P_0$$

and the average photo current:

$$\langle i_{ph} \rangle = \frac{\eta \cdot q}{\hbar\omega} \cdot P_0$$

Because of processes which are typical for semiconductors there is already a current flowing even if there are no photons entering the detector. This current is called „dark“ current and has four reasons:

1. Diffusion current, it is created because of statistical oscillations of the charge carriers within the diffusion area
2. Regeneration or recombination current, it is generated by random generation and annihilation of holes
3. Surface currents, which are hardly avoidable since the ideal insulator does not exist
4. Avalanche currents are flows of electrons which appear at high electric field strengths, if, for example, a high voltage is applied to the photodiode

All these effects contribute to the dark current  $i_D$  in a way that finally the characteristic curve of the diode can be expressed as follows:

$$i = i_s \left( e^{\frac{q \cdot U_D}{kT}} - 1 \right) - \langle i_{Ph} \rangle = i_D - \langle i_{Ph} \rangle$$

This current  $i$  passes the load resistor  $R_L$  and provokes the voltage drop  $U_a$ , which represents the signal.

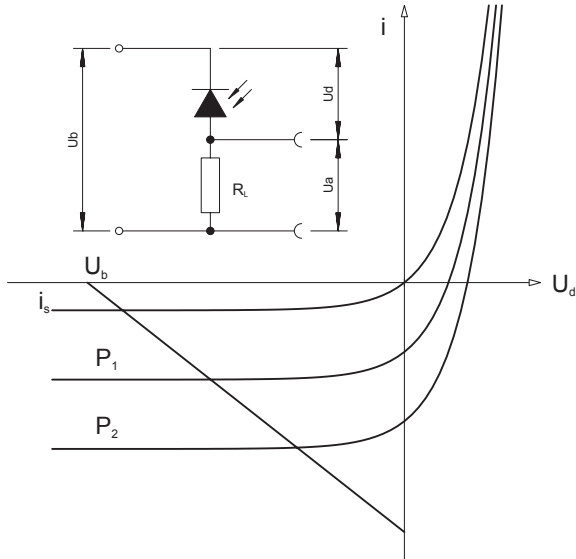

Fig. 26: Characteristic line of a photodiode in the photoconductive mode

$$i = i_s \left( e^{\frac{q \cdot U_d}{kT}} - 1 \right) - \langle i_{Ph} \rangle = \frac{U_a}{R_L}$$

A good detector of optical communication technology is characterised by the fact that it is very fast ( up to the GHz range ) and that it has a high quantum efficiency which means that it is very sensitive. Depending on the wavelength range which has to be covered by the detector one uses silicon or germanium semiconductor material for the construction of the detectors.

### 2.1 Ge and Si PIN-diodes

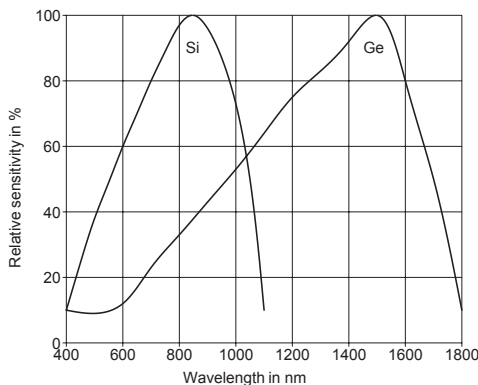

Fig. 27: Relative sensibility for Si and Ge photo detectors

To have absorption of a photon at all its energy has to fit into the band structure of the material under consideration. From the condition

$$E_{ph} = \hbar \omega = h\nu = \frac{hc}{\lambda} \geq E_G$$

one recognises that for large wavelengths the energy of the photon may no more be sufficient „ to lift“ the electron

in a way that it passes the band gap. For smaller wavelengths one has to respect that the conduction band and also the valence band have upper edges which is followed by a band gap. Photon energies which pass the upper limit of the conduction band can no more be absorbed. The wavelength of the applied light source decides which detector material is to be used. For wavelengths above 1  $\mu\text{m}$  up to 1.5  $\mu\text{m}$  Germanium is recommended. Underneath these values Silicon detectors are used. In the present experiment a laser diode of 810 nm wavelength is applied. Therefore a silicon detector is used. To get a high quantum efficiency not a PN but a PIN detector has been chosen.

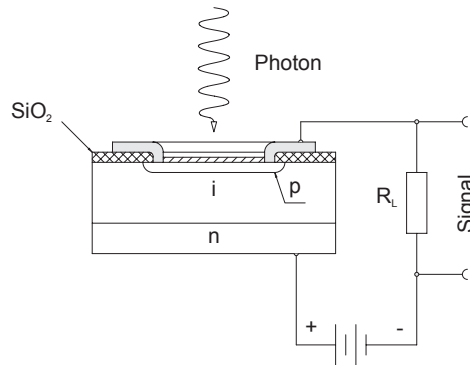

Fig. 28: Design of a PIN detector

Contrary to a detector with a simple pn-layer this type of detector has an intrinsic conducting layer inserted in between the p-and n-layer. Therefore the name PIN-diode. The reason for this is to enlarge the barrier layer which increases the probability of absorption of a photon and the generation of a current impulse, e.g. the quantum efficiency. The quantum efficiency for such an arrangement is:

$$\eta = (1 - R) (1 - e^{-\alpha d}) e^{-\alpha d_p}$$

$R$  is the Fresnel reflection at the Si or Ge surface which is hit by the photons,  $\alpha$  is the coefficient of absorption,  $d$  the thickness of the intrinsic zone and  $d_p$  the thickness of the p-layer. By attachment of a reflex reducing layer on the upper side of the p-layer  $R$  can get a value of less than 1%. Since  $\alpha d_p$  is anyhow  $\ll 1$ , the thickness of the intrinsic layer should be chosen as large as possible. The consequence of this is that the drift time rises and the limiting frequency of the detector is reduced. In so far a compromise between high quantum efficiency and high limiting frequency has to be made. In this experiment a PIN-Si-photo diode, type BPX61 is used. It has the following characteristic values:

Quantum efficiency $\eta$ at 850 nm	90 %
Rise time $T_r = 2.2 R_L C_j$ 10%-90% at $R_L = 50 \Omega$ and $U_d = 10V$	1.7 ns
Capacity $C_j$ at $U_d =$	
0 V	73 pF
1 V	38 pF
10 V	15 pF
dark current $i_d$ at $U_d = 10V$	2 nA
Photosensitivity at $U_d = 5V$	70 nA/lx

### 3.0 Diode laser and Nd:YAG

Excitation by optical pumping has developed as a very important method used in spectroscopy. It is also an indispensable technique for the excitation of a number of different types of lasers. Optical pumping in conjunction with Nd-YAG lasers is of particular interest, because these have become widely accepted for industrial use, along with the CO<sub>2</sub> laser. The laser-active material which, in the case of the Nd-YAG laser, is excited by optical pumping, consists of neodymium atoms that are accommodated in a transparent host crystal (YAG = Yttrium Aluminium Garnet). Whereas up to a few years ago Nd-YAG lasers were almost excited using discharge lamps, optical pumping with laser diodes is becoming more significant. This is because laser diodes are available economically and they emit narrow band light at high optical powers, which matches the energy levels of the Nd-YAG crystal (Fig. 29). The advantage over the discharge lamp is that the emission of laser diodes is nearly completely absorbed by the Nd-YAG, whereas the very wide spectral emission of discharge lamps is absorbed to only a small extent.

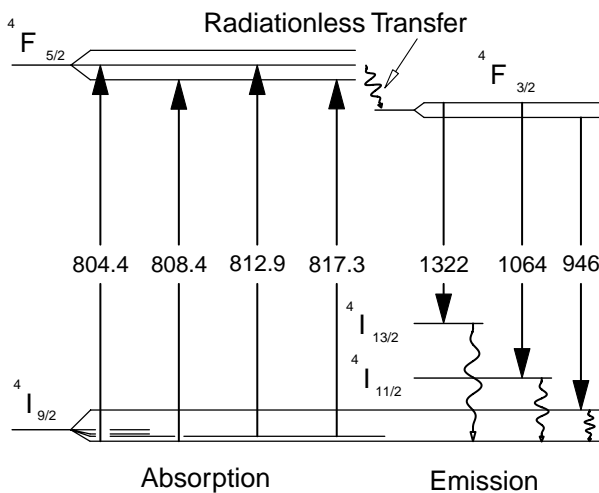

**Fig. 29: Relevant energy levels of Nd-YAG for optical pumping with laser diodes having wavelengths around 805 nm.**

The efficiency of optical pumping with discharge lamps is about 3%, but figures of up to 50% can be achieved using laser diodes! Some energy levels of the Nd atom are illustrated in Fig. 29. Here, only those are shown which are significant for optical pumping with laser diodes and which are important for the laser process. The levels are labelled with their spectroscopic notations. Since the Nd atoms are situated within the YAG host crystal, the otherwise degenerated energy levels of the isolated Nd atom split into a number of states. This gives rise to the ground state 4I<sub>9/2</sub> from 5 substates and the state 4F<sub>5/2</sub>, which can be pumped from 5 substates. Since the wavelength of the pump-light source (diode laser) can vary within low limits, a total of three to four transitions can be pumped with high efficiency. The Nd atoms of the 4F<sub>5/2</sub> state pass very quickly into the laser output level 4F<sub>3/2</sub>. The laser transition which is technically most interesting takes place between the 4F<sub>3/2</sub> state as starting level and terminates in the 4I<sub>11/2</sub> state with an emitted wavelength of 1064 nm. From here the Nd atoms relax again into the ground state 4I<sub>9/2</sub> until the pumping process starts from the beginning

again. The Neodymium therefore has an ideal four level system. The principle is shown in Fig. 30. Under the radiation of a light field (optical pumping), transitions from ground state 1 to the upper level 4 occur. The reverse processes from state 4 to state 1 are prevented by very fast transitions from state 4 to state 3 without radiation. The laser transition takes place from level 3 into level 2 which is thermally not populated. From here the Nd atoms relax again back to ground state 1.

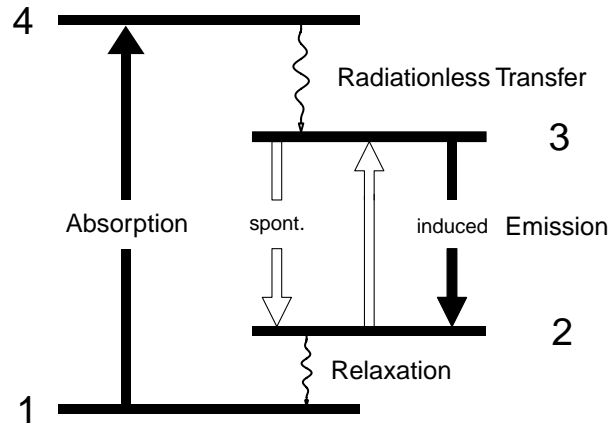

**Fig. 30: Principle of the four-level laser**

The irradiation by light, which leads to the population of an otherwise empty state, is termed optical pumping. The emptying of a level occurs either with the emission of photons or without radiation. Transitions without radiation take place due to mechanical interactions such as collisions or vibrations and they are also designated as relaxation.

The number of transitions without radiation per second is termed the relaxation rate. Transitions in which photons are emitted occur spontaneously or are induced. Spontaneous transitions also occur without pumping processes. However, induced emissions only occur if a pumping process takes place.

Rates are also stated here, one rate for spontaneous emission and another one for induced emission. Each state which can interact with one or more other states is labelled with this type of rates.

However, in Fig. 14 showing the principle, only the transition probabilities that are significant for the pump and laser processes are indicated.

All the designated levels are populated to some extent due to pumping. The extent to which each state is populated is given by the number  $N_i$  of Nd atoms which are in the relevant state  $i$  of excitation:

State 1	$N_1$
State 2	$N_2$
State 3	$N_3$
State 4	$N_4$

Under the realistic assumption made in this example that the Nd atoms only pass through the labelled excitation steps, the sum of the population densities gives the Nd atoms which are available.

The desired laser oscillation will, however, only be achieved if an adequate population inversion can be established between states 3 and 2.

The conditions under which laser emission occurs, together with how the laser behaves, can be predicted by a model of the so called rate equation model.

The main interest of this experiment however is to determine the wavelength of the laser diode by use the well known absorption lines of the Nd-YAG. The energy level diagram for Nd ions in the YAG host crystal was shown in Fig. 13. According to this diagram, there are four absorption transitions which can be pumped with the laser diode used here. The maximum points of the absorption are located at:

1. 804.4 nm
2. 808.4 nm
3. 812.9 nm
4. 817.3 nm

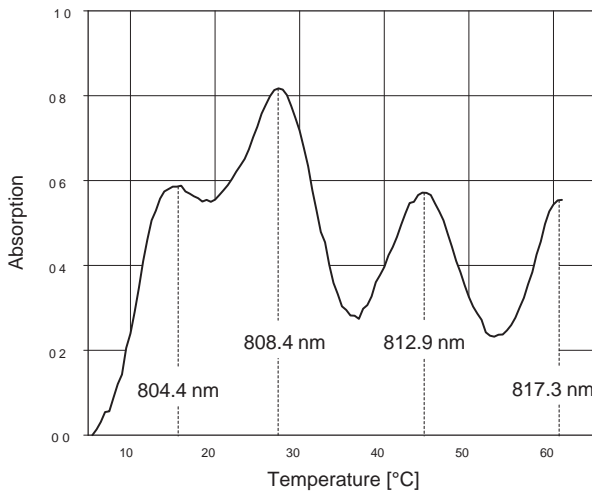

**Fig. 31: Absorption measurements for Nd-YAG versus the temperature of the laser diode**

The YAG rod is used in addition to the existing set-up for the measurement of the wavelength dependence. The YAG rod should be positioned such that the laser light illuminates the YAG rod centrally. The supplied photo detector is positioned behind the YAG rod.

The distance should be chosen in such a way that the light intensity does not saturate the detector. The photo detector is connected to the amplifier of the controller unit LDC-01. The related output can be connected to the voltmeter or an oscilloscope. Attention must be given in sensitive ranges to ensure that no extraneous light invalidates the measurement. At the start of the measurement the semiconductor laser module is switched on again. The residual pump light passing through the YAG rod can be observed with the converter screen.

If the diode temperature is now changed, an increase or decrease in the intensity of the residual light can be observed which is caused by the wavelength dependence of the semiconductor laser.

Once set, the level of injection current must be maintained when carrying out the following measurement, because it also affects the wavelength and the output power. The measurement is taken, beginning with the lowest possible temperature. A period of a few minutes must expire before the laser diode has cooled down to a constant value. The measurements are then taken in suitable temperature steps up to the maximum temperature.

If the measurements are recorded, the spectrum showing dependence of absorption in temperature is obtained for the Nd-YAG material.

At least three or even four peaks should arise which can be allocated to the well known central wavelengths.

A practical method is, to first of all, set the temperature at which the absorption was the highest or at which the transmission was the lowest. This value should then be at the known central wavelength.

The injection current is then varied, changing the temperature so that maximum absorption occurs again. The pair of values for temperature and injection current are noted and drawn graphically.

A straight-line operational characteristic is obtained for which the wavelength is constant (Fig. 16).

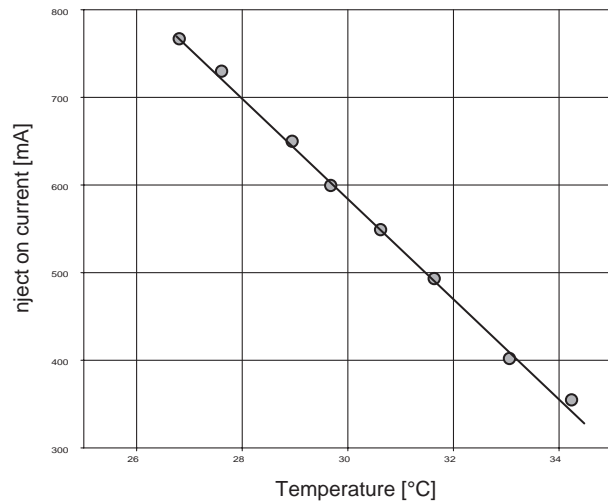

**Fig. 32: Laser diode characteristic for operation at constant wavelength**

## 4.0 Experiment

### 4.1 Set-Up

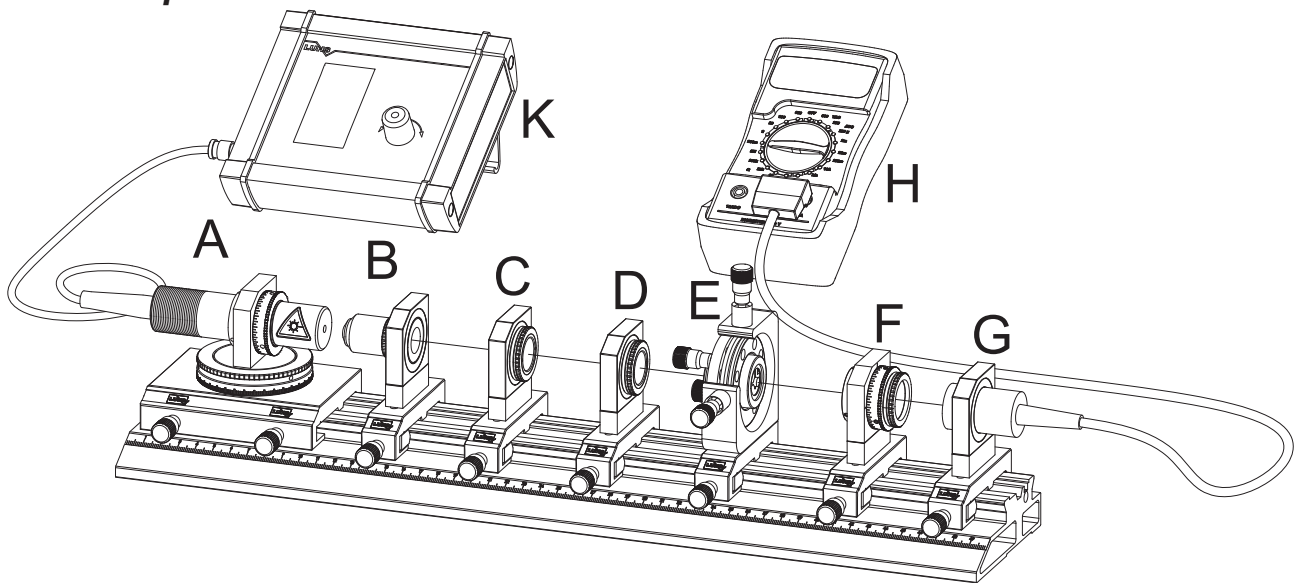

### 4.2 Description of Modules

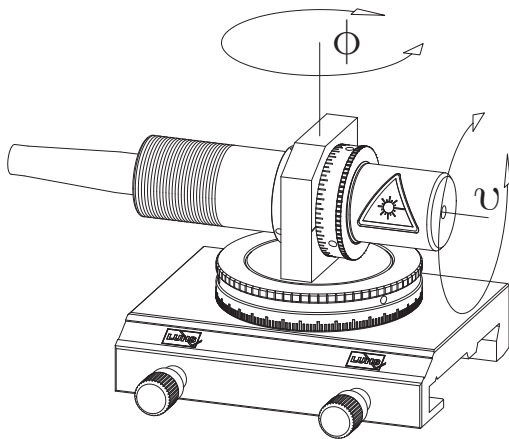

#### Module A

A laser diode of 30 mW at 808 nm is mounted onto a Peltier cooler. The temperature is measured by means of an integrated thermistor. The laser head itself is mounted in a mounting plate on carrier in such a way that it can be rotated around the laser axis ( $\nu$ ) as well as vertical to the axis ( $\phi$ ).

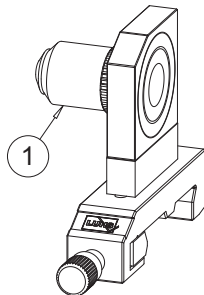

#### Module B

Collimation optics for the diodelaser consisting of an achromatic microscope objective 10 x (1) and a mounting plate on carrier.

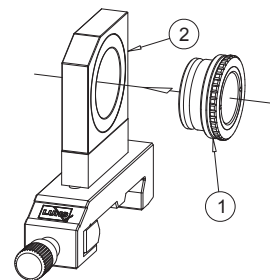

#### Module C

Optics for beam shaping consisting of a cylindrical lens with  $f=20$  mm mounted in a click mount (1) and a mounting plate on carrier (2).

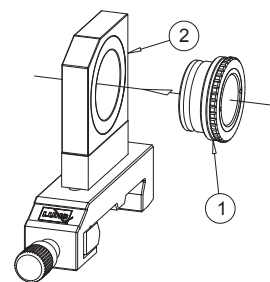

#### Module D

Optics for beam shaping consisting of a cylindrical lens with  $f=80$  mm mounted in a click mount (1) and a mounting plate on carrier (2).

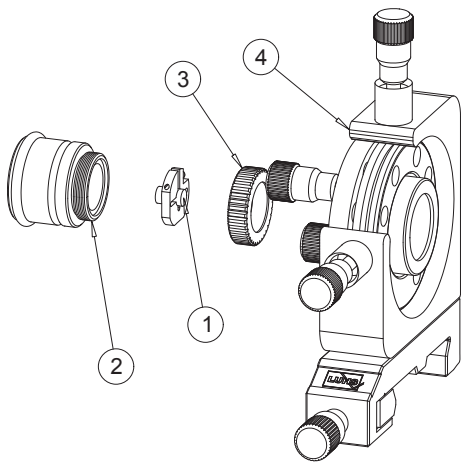

**Module E**

A Nd:YAG rod (1) is mounted in a fixation disk. By means of the cap screw (3) the disk is mounted to the holder (2). The mounted Nd:YAG rod is placed into the adjustment holder (4). The well known absorption lines of the Nd:YAG material are exploited as wavelength selective element.

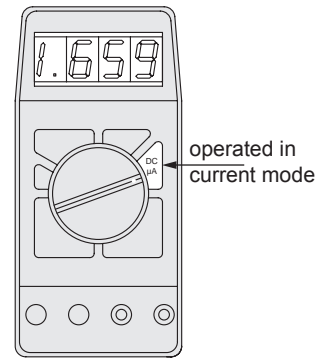

**Module K**

Digital voltmeter to be connected to the photodiode. It will be operated in the current mode since the photocurrent is linear to the light intensity.

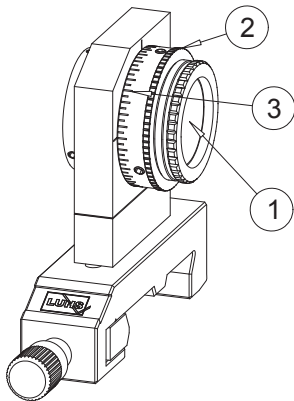

**Module F**

Polarisation analyser (1) is mounted into a rotatable holder (2). The rotation angle can be read on a scale (3) for each 5°. The entire unit is mounted onto a carrier to be placed onto the optical rail.

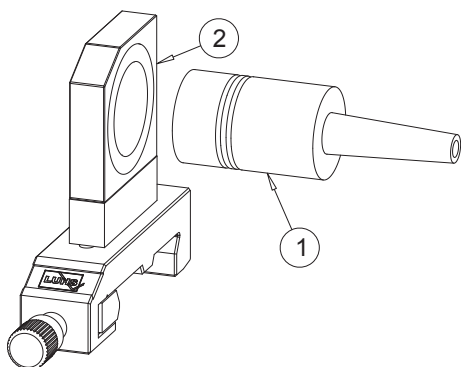

**Module G**

A PIN - photodiode is mounted in a housing with „click“-grooves (1). By means of the attached cable the detector is connected to the digital meter module K. The detector is „clicked“ into the mounting plate (2).

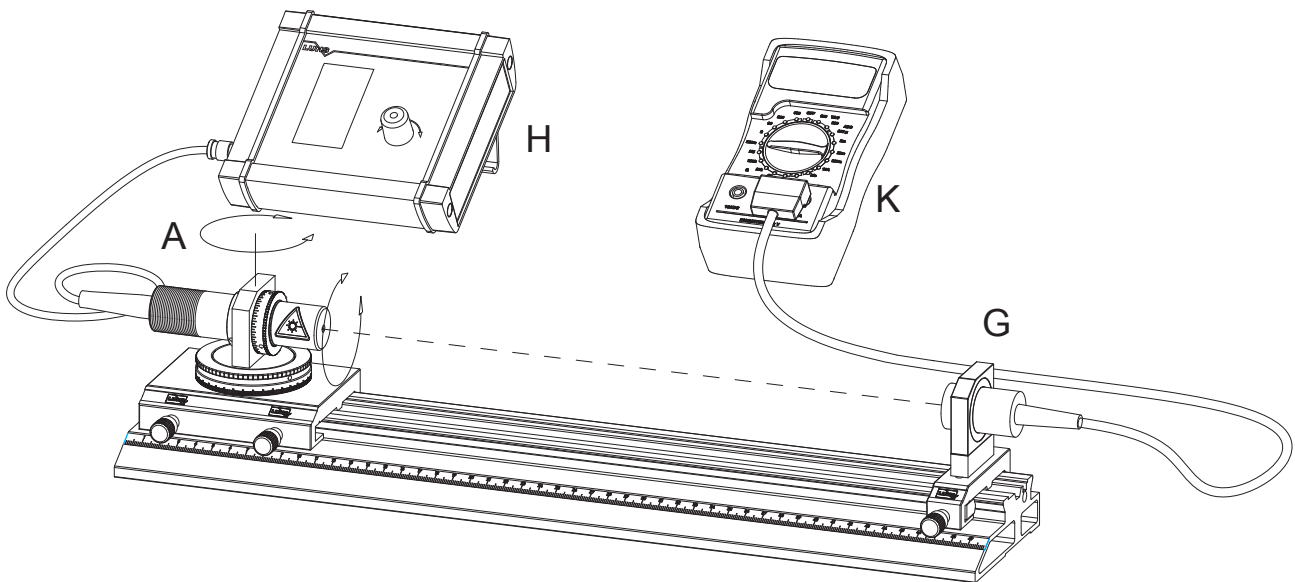

### 4.3 Spatial Beam Distribution

With the above set-up the beam geometry of the laser diode will be measured. The module A (laser diode with two axes rotational stage) and the photo detector (module G) are used.

The laser diode can be turned around its optical axis as well perpendicular to it. Turning the diode around its optical axis is provided to align the diodes elliptical beam cross section with respect to the plane of the other rotational stage. By rotating this stage the angle resolved intensity distribution of the laser diode emission is been measured.

The photo detector is connected to multimeter (module K) which is switched to DC current mode.

One has to make sure, that the detector will not be satu-

rated by the laser light.

Of course the detector can also be connected to an oscilloscope. In this case the modulator of the control unit can be activated for producing a rectangular AC signal.

Within the same set-up the dependence of the laser power versus injection current and temperature can be measured.

In addition the behaviour of the laser diode is measured when it is modulated by the internal modulator with a rectangular amplitude. For this purpose the modulator is activated within the selection menu of the controller H. The provided TTL signal of the modulator of the controller H can be connected to the oscilloscope and used as trigger source.

## 4.4 Wavelength Dependence

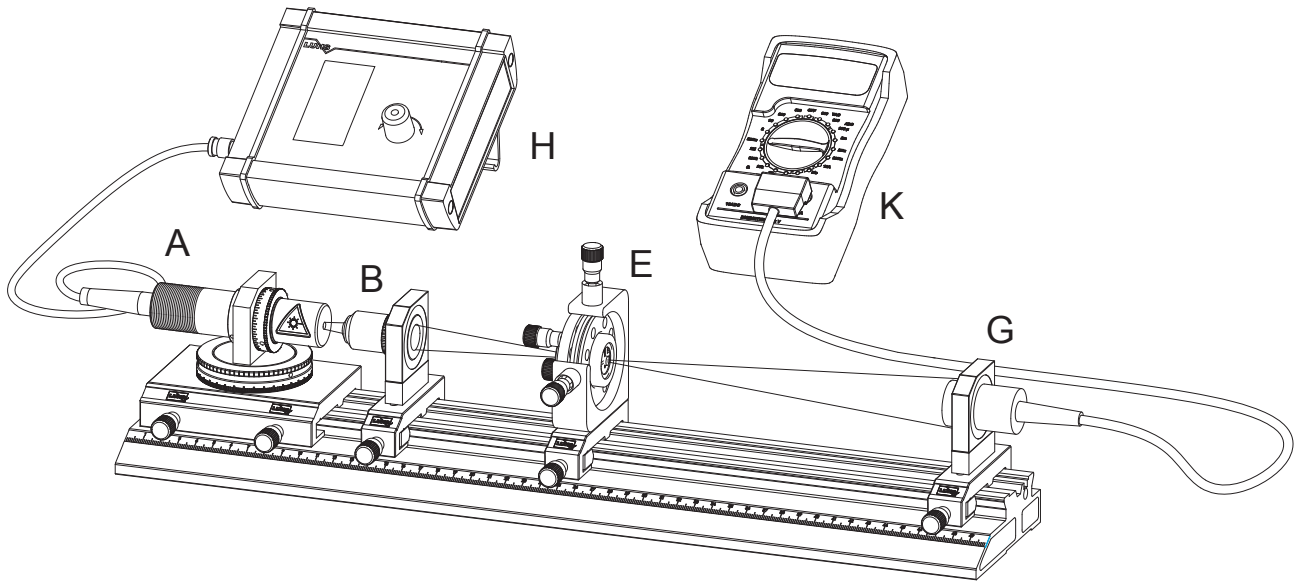

From the previous chapters it is known that the wavelength of a laser diode is determined by the maximum gain and the optical length of its resonator, which in turn depends on the temperature and the optical density inside the resonator relying on the injection current.

The goal of this experiment is the measurement of these relations.

To determine the wavelength, the Nd:YAG rod with its well known absorption transitions will be used. The rod is mounted into the module E and has a diameter of 5 mm and a length of 5 mm. The beam of the diode laser is focused by means of the module B into the rod. For different temperatures of the laser diode the maximum of absorption will be determined. The corresponding wavelength is taken from the known transitions. Once located a maxi-

mum of absorption temperature and current are varied in such a way that one stays at the same value of absorption. For each couple of injection current and temperature the curve for constant wavelength is drawn. Using the linear regression the coefficients  $\alpha(I)$  and  $\alpha(T)$  are derived.

Thereby one has to obey that the output power of the laser diode also depends on the temperature, which has to be measured first. The variation of the temperature should be small enough to ensure not to leave the chosen absorption transition.

Care also has to be taken not to saturate the detector by too high laser power. The polarisation analyser can be used to attenuate the power.



### 4.5 Wavelength Measurement with a Spectrum Analyser

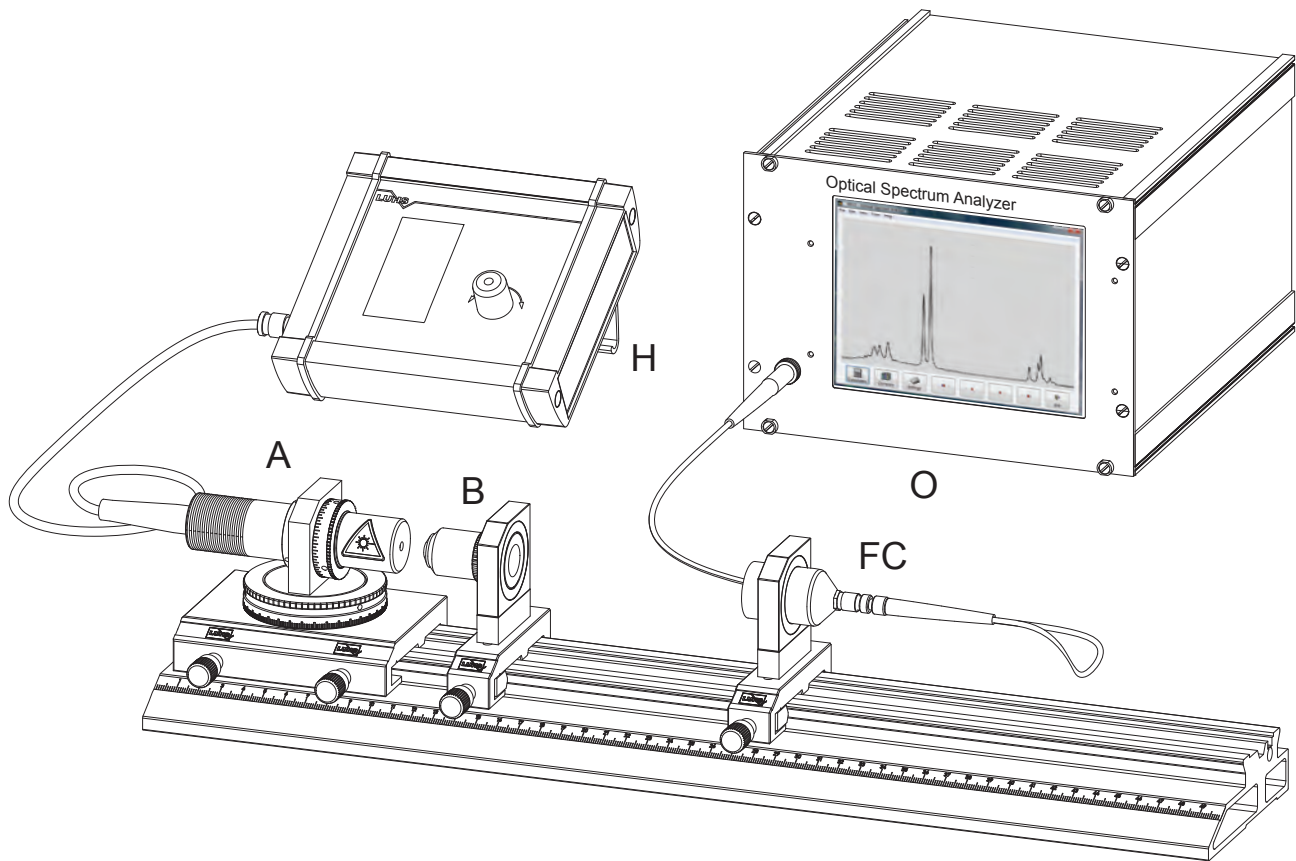

If the optional spectrum analyser (O) is available a series of additional experiments can be carried out. The derivation of the curve for constant wavelength is carried out in the same way. But now a fixed adjusted wavelength of the analyser will be used instead of the Nd:YAG rod. Because of the relative small dependence of the wavelength versus the injection current approximately 0.025 nm/mA the resolution is not that good as in the case using the Nd:YAG rod. More over the analyser offers the possibility to measure the complete emission spectra of the laser diode for

different values of temperature and injection current. If one is interested in the emission processes within the Nd:YAG crystal the excitation spectra can be taken. For this case again the Module E is used and the laser radiation is focused into the rod. By means of an additional lens the generated fluorescence light is directed onto the lens of the fibre coupler FC of the analyser. For this purpose both cylindrical lenses can be used.

## 4.6 Polarisation

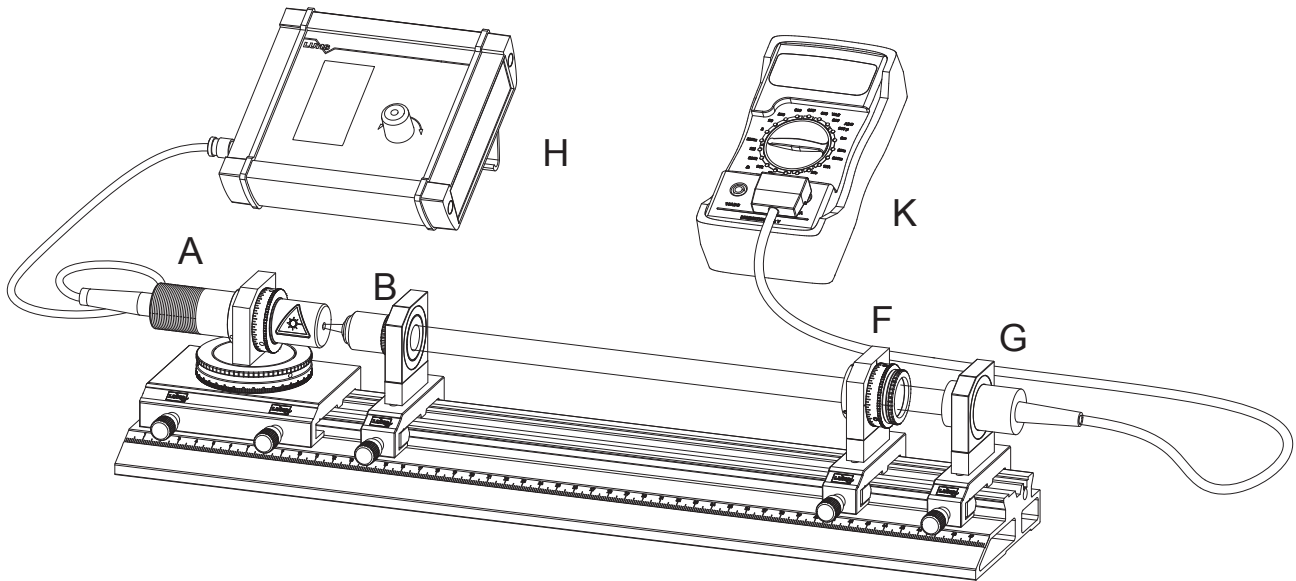

To the previous set-up the module F is added. The module consists of a rotational stage for rotating and reading the angle position of the polariser mounted into the stage. Take care that the detector will not be saturated. To obtain unambiguous polarisation states with respect to the polarisation analyser the laser light of the diode is collimated by means of the module B containing the focussing optics. The parallelism of the beam is checked with the IR screen and adjusted by the distance of the module B from the di-

ode. The polarisation analyser is turned to a position for a sufficient signal. Now the injection current is varied and the intensity behind the analyser is measured. Of major interest is the region around the threshold, where the diode turns from the LED into the laser operation.

## 4.7 Beam shaping

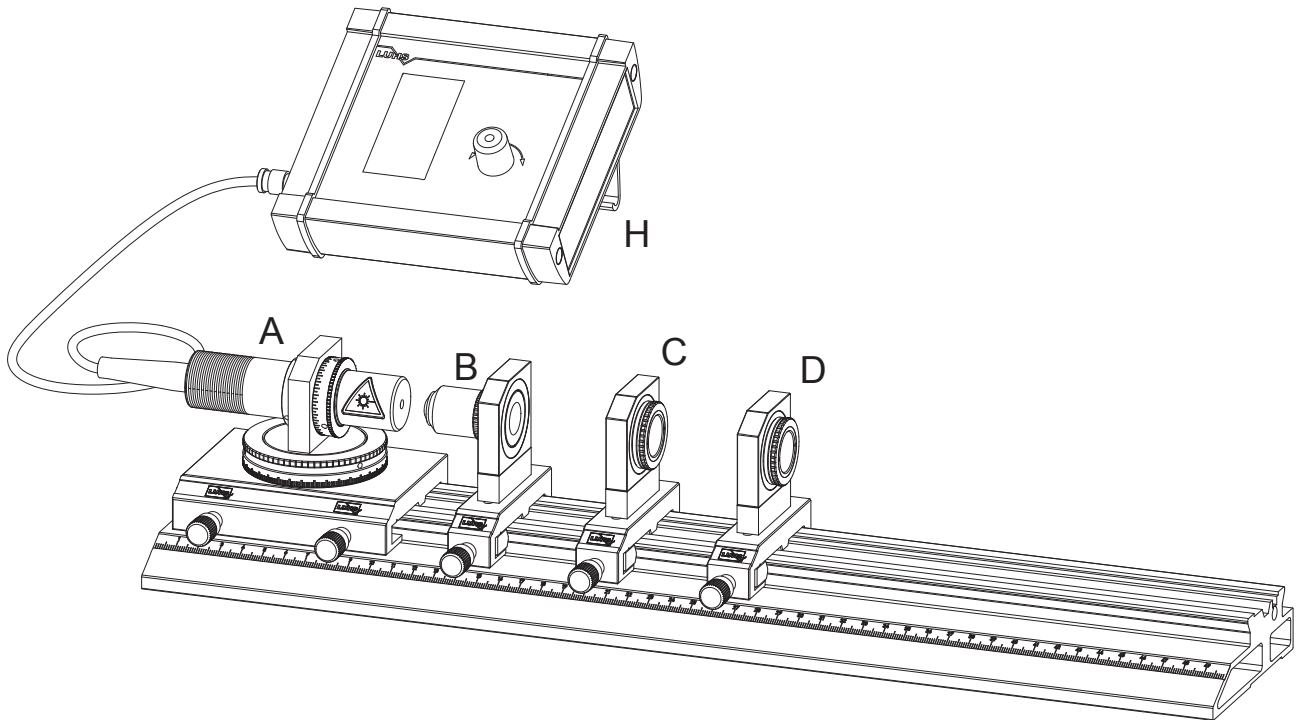

From the basics and carried out measurements it is known that the emitted beam of the laser diode exhibits a more or less strong divergence which in addition poses a significant astigmatism.

Within this optional experiment different sets of lenses shall be used to correct the beam.

Without optics which corrects for these errors, the use of diode lasers is very limited. Applications of laser diodes are only successful if one is able to transform the beam into the desired shape.

For this reason in this experiment three different optical elements are used:

module B	Microscope objective	$f=8.2$ mm
module C	cylindrical lens	$f=20$ mm
module D	cylindrical lens	$f=80$ mm

With these elements a series of different layouts can be realised:

e.g.

beam shaping with crossed cylindrical lenses

with collimator B and cylindrical lens telescope generation of smallest possible beam waist with cylindrical lens C, lens B and cylindrical lens D.

The last arrangement is used for mode matched optical pumping of Nd:YAG lasers.

## 4.8 Digital Laser Diode Controller

This fully digital operating device controls the injection current as well as the temperature of the diode laser head. By means of a one knob interaction all parameters can be set and displayed. By turning the knob a specific menu item is selected. Pressing the knob acts as enter key.

The diode laser head is connected via a multi-pin connector to the device. A BNC jacket provides a synchronisation signal of the modulation frequency when the diode laser is electronically switched on and off. The ED-0020 device provides an integrated USB interface which enables full remote control by an optional computer or laptop.



### Specifications:

Injection current	1000 mA maximum, selectable in steps of 10 mA
Temperature	15 - 40 ° C in steps of 1°
Modulation	10 to 1000 Hz in steps of 10 Hz
Operating Voltage	12 VDC, by means of an extra wall plug power supply
Inputs	Diode laser connection
Outputs	Modulation signal as TTL trigger signal via BNC jacket
Dimensions	115 x 130 x 38 mm

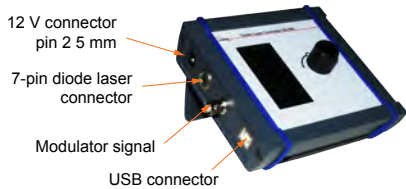

Fig. 33: External connections

On the left side of the ED-020 the connectors are located. A 12 V connection with 2.5 mm pin is provided. A simple wall plug power supply is attached to here. The diode laser connection requires a 7 pin connector and is suited for the DIMO 0.5 W laser head with integrated Peltier's element and NTC temperature sensor. However also other laser heads may be connected, please feel free to ask for our support. A BNC jack is provided to deliver a monitor signal for the internal modulator. This signal can be used as trigger. The USB connector is provided for future expansions to control the unit by external software.



### Laser ON / OFF

Turning the central knob highlights sequentially the selected item. To switch the laser on, turn the knob until the "Laser" menu is highlighted as shown in the figure on the left side. Pressing the central knob shortly (less one second) switches the laser on or off.

If a previous value of the current has been set and the laser is switched of, the processor provides a soft shut down of the laser diode.

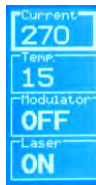

### Injection current

Select the "Current" menu and press the central knob down for 2 seconds until the "Current" item starts to blink. By turning the knob the current is selected which is set to the laser diode from the processor with soft steps of 10 mA in 100 ms. This assures a safe and lifetime extending operation for the laser diode. Pressing again the central knob leaves and closes the current menu.



### Temperature

Select the "Temp." menu and press the central knob down for 2 seconds until the "Temp." item starts to blink. By turning the knob the temperature set point is selected. To take over the value the central knob must be pressed as long as the menu item "Temp." stops blinking. The temperature range can be set in from 15° up to 35° C. In highlighted mode the value of the temperature is the temperature set point. In non highlighted mode the actual temperature is displayed. It may take a while before the system reaches the stable temperature.



### Modulator

The injection current can be switched periodically on and off. In this mode the output power of the laser diode is modulated as well. This is of interest, when time dependant measurements shall be carried out. The modulation frequency can be set from 0 to 1000 Hz. The duty cycle is fixed to 50%. A monitor signal of this modulation signal is present as TTL signal at the BNC jack as shown in the Fig. 31.

### 5.0 Laser safety

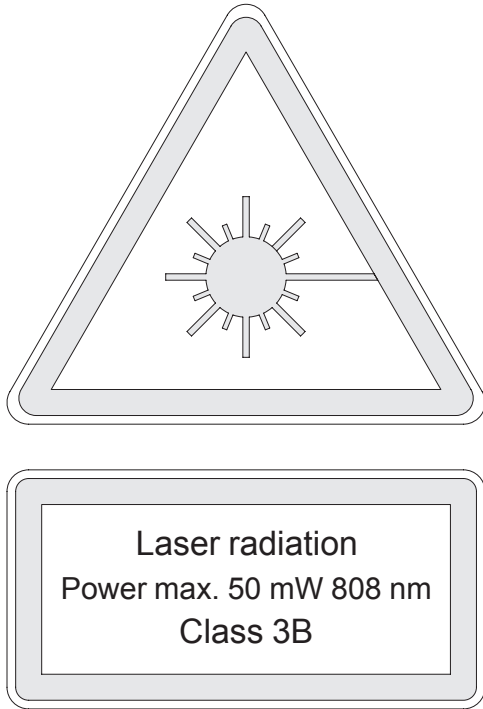

This set-up contains a diode laser which is only suitable for laboratory applications.

With the individual modules in the assembled state, laser radiation (semiconductor laser) can be produced at 805 nm with a maximum power of 30 mW.

The complete assembled laser is therefore a product which exhibits the power characteristics of a Class 3B laser. Since the EXP01 is a laser system formed from combined modular elements and can therefore be modified in a number of different ways, the operator of this system must ensure that the safety requirements are met.

The manufacturer only provides a guarantee for the individual modules, but does not accept any responsibility for cases of damage which arise due to the combination of the modules. The user must observe the laser safety regulations, e.g. **DIN VDE0837** or **IEC 0837**.

In these guidelines of February 1986 the following points are listed for the operation of laser equipment in laboratories and places of work.

#### Laser equipment in laboratories and places of work

##### Class 3B laser equipment

Class 3B lasers are potentially hazardous, because a direct beam or a beam reflected by a mirror can enter the unprotected eye (direct viewing into the beam). The following precautions should be made to prevent direct viewing into the beam and to avoid uncontrolled reflections from mirrors:

a.) The laser should only be operated in a supervised laser area

b.) Special care should be taken to avoid unintentional reflections from mirrors

c.) Where possible the laser beam should terminate on a material which scatters the light diffusely after the beam has passed along its intended path. The colour and reflection properties of the material should enable the beam to be diffused, so keeping the hazards due to reflection as low as possible.

Note: Conditions for safely observing a diffuse reflection of a Class 3B laser which emits in the visible range are : Minimum distance of 13 cm between screen and cornea of the eye and a maximum observation time of 10s. Other observation conditions require comparison of the radiation density of the diffused reflection with the MZB value.

d.) Eye protection is necessary if there is a possibility of either direct or reflected radiation entering the eye or diffuse reflections can be seen which do not fulfil the conditions in c.).

e.) The entrances to supervised laser areas should be identified with the laser warning symbol

MZB means Maximum Permissible Radiation (Maximal zulässige Bestrahlung) and it is defined in section 13 of DIN/VDE 0837.

Special attention is drawn to point 12.4 of DIN VDE0837:

#### Laser equipment for demonstration, display and exhibition purposes

Only Class 1 and Class 2 lasers should be used for demonstrations, displays and exhibitions in unsupervised areas. Lasers of a higher class should then only be permitted if the operation of the laser is controlled by an experienced and well trained operator and/or the spectators are protected from radiation exposure values which does not exceed the applicable MZB values.

Each laser system, which is used in schools for training etc. should fulfil all the applicable requirements placed on class 1 and class 2 laser equipment; also, it should not grant persons access to radiation which exceeds the applicable limits in Class 1 or Class 2.







[WWW.LD-DIDACTIC.COM](http://WWW.LD-DIDACTIC.COM)



LD DIDACTIC distributes  
its products and solutions  
under the brand LEYBOLD

**LEYBOLD®**